

57
January
1988

elektor **INDIA**

152
Rs. 8.00

electronics

**TEST & MEASURING
EQUIPMENT**

**MULTI-FUNCTION
FREQUENCY METER**

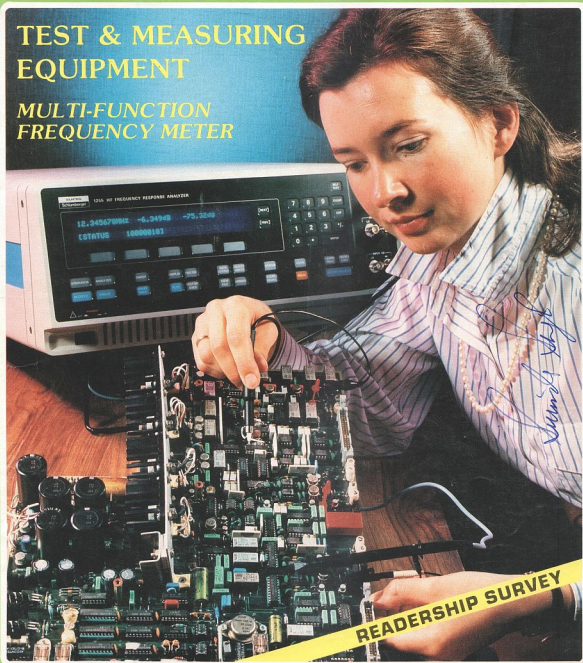

READERSHIP SURVEY

Publisher: C.R. Chandarana
Editor: Surendra Iyer
Technical Editor: Ashok Dongre
Circulation: J. Dhas
Advertising: B.M. Mehta
Production: C.N. Mithagari

Address:
 ELEKTOR ELECTRONICS PVT. LTD.
 52, C Proctor Road, Bombay-400 007 INDIA
 Telex: (011) 76661 ELEK IN

Overseas editions:

Elektor Electronics
 1, Harlequin Avenue,
 Great West Road, Brentford TW8, 9EW U.K.
Editor: Len Seymour

Pulitron Publicacoes Tecnicas Ltda
 Av Ipiranga 1100, 9º andar CEP01040 Sao Paulo — Brazil
Editor: Juliano Barsali

Elektor sari
 Route Nationale, Le Saut, B.P. 53
 592270 Baillieu — France
Editors: D R & Meyer,
 G C P Raedersdorf

Elektor Verlag GmbH
 Susterfeld-Str. 25 100 Aachen — West Germany
Editor: E J A Krempelsauer

Elektor EPE
 Karaiskaki 14 16673 Voula — Athens — Greece
Editor: E Xanthoulis

Elektuur B.V.
 Pieter Triekpoelstraat 2 4
 6191 VK Beek — The Netherlands
Editor: P E L Kersemakers

Ferreira & Banto Lda
 R.D. Estefania, 32 1º 1000 Lisboa — Portugal
Editor: Jorge Goncalves

Ingelek S.A.
 Plaza Republica Ecuador 2 28016 Madrid Spain
Editor: A M Ferrer

In Part:
 Kedhorn Holdings PTY Ltd Cnr Fox Valley Road &
 Kugle Street Wahroonga NSW 2076 — Australia
Editor: Roger Harrison

Electronic Press AB
 Box 63
 182 11 Danderyd - Sweden
Editor: Bill Cedrum

The Circuits are for domestic use only. The submission of designs of articles of Elektor India implies permission to the publisher to alter and translate the text and designed and to use the contents in other Elektor publications and activities. The publishers cannot guarantee to return any material submitted to them. All drawings, photographs, printed circuit boards and articles published in Elektor India are copyright and may not be reproduced or imitated in whole or part without prior written permission of the publishers.

Patent protection may exist in respect of circuits, devices, components etc. described in this magazine.

The publishers do not accept responsibility for failing to identify such patent or other protection.



MEMBER

Printed at : Trupti Offset: Bombay - 400 013

Ph. 4923261, 4921354

Copyright © 1987 Elektor B.V.

CONTENTS

Electronics Technology

Mathematical Principles of Natural Philosophy by Isaac Newton	1.32
Information theory and Encryption	1.35
Electronic & Magnetic Quantities	1.36
Numbers and the machine	1.45
What is Watt?	1.55

Projects

LCD VU Meter	1.22
Stereo pan pot	1.34
Multi-function Frequency Meter	1.41
Multiple voltage supply	1.48
Top-of-the-range preamplifier (3)	1.49

Test & Measuring Equipment

Dual-trace Oscilloscopes (A) Part 1	1.26
Elektor india Test Equipment	1.54

Readership Survey

We ask all our readers to take a few minutes to answer the 20 questions in our Readership Survey	1.39
--	------

Information

Electronic News	1.17
Telecommunication News	1.20
New Products	1.62
Readers Services	1.72

Guide lines

Switch board	1.69
Index of advertisers	1.74

Selex-30

Charging/Discharging Current Meter	1.58
Power Amplifier	1.60

INDO-ARAB CABLE LINK

The India-United Arab Emirates submarine cable communication link was commissioned recently. This telecommunication facility is in addition to the already existing International Subscriber Dialed service and the bureaufax facility for facsimile transmission of documents within seconds.

The India-UAE cable system is a joint international communication project with costs being shared by both the countries. The system uses a coaxial cable connecting Bombay and Fujairah. It provides 1380, two-way grade circuits. The total length of the cable is 1964 km.

The international telecommunication traffic stream between India and the UAE is one of the largest next only to the UK and the USA. About 250,000 Indians live in the UAE. The Videsh Sanchar Nigam Limited (VSNL) formerly known as the Overseas Communication Service of India and the Emirates Telecommunications Corporation Ltd. have jointly planned and implemented the submarine cable project.

While satellite communication was already providing reliable wide band communication capacities, there were still certain drawbacks like the propagation delay of the order of 250 milliseconds on each satellite hop and the susceptibility of microwave satellite

transmission to external interference. It is an international practice to provide alternate transmission medium in case of failure of any one system. This view was shared by both the governments and the submarine cable project work took birth in 1981.

By this time, optical fibres emerged as a contender for the conventional coaxial cables. But, optical communication technology was proven only on short routes. Further, costs involved were too high for the required circuit capacity. Hence, conventional technology was chosen for the India-UAE link. A memorandum of understanding was signed by both the countries in 1984. The total cost of the project is Rs. 80 crores.

When this project was put for global tender Japan and USA did not respond as manufacturers in those countries were no longer producing copper trunk submarine cables. They switched over to fibre optic cables. Standard Telephone and Cable company of the UK was given the contract for supply, installation and commissioning of the system and in 13 months the project was completed.

The light weight unarmoured cable is used where the depth of the sea exceeds 800 metres. The off-shore and fishing activities are more likely in coastal area and the cable laid in such regions face hazards. Outside sheath of the cable is armoured with

high tensile steel wires for protection. Double armoured cables are used in shallow waters. In some portions, the cable is laid as below as 3550 metres in the Arabian Sea.

Initially, investigation of sea and bed profile, sub-bottom stratum, cable fault histories, water temperature and its quality offshore and fishing activities etc. had been carried out to determine the basic route. During the survey prior to the laying of the cable, sea bottom profile, topography of sea bed, quality and temperature of sea water, seismic activity, under current, reefs and wrecks, marine plantation and navigational data were collected.

As a result of advances in micro-electronics and computers which are being integrated with communication systems, the capital cost of submarine cable circuit has come down drastically. The capital cost per channel kilometre in 1956 was 580 dollars. It came down to 70 dollars in 1965 and in 1987, it cost just 22 dollars.

The first fibre optic submarine cable will be commissioned across the Atlantic in 1988. It will have a capacity of 40,000 circuits. Instead of a repeater for every 25 km in a copper cable, optical fibre requires repeater once every 150 to 200 km.

The first cable laid in 1956 was retired last year after 30 years of service because there was no need to maintain it for the meagre 36 circuits provided by it. Satellites require

replacement every seven years and next generation satellite may last for 14 years. Satellites, dependable during peace, can become a security risk during global wars. In the 130 years of submarine cable history, no cable was damaged due to enemy action. They could not be tapped unlike satellite communication. However, satellites have no rival for providing communication to inaccessible and inhospitable places.

India had its first submarine cable for telecommunications in 1869-70 when the Eastern Telegraph Company of UK laid a cable connecting Suez-Aden-Bombay.

The first submarine cable of India was commissioned in 1981, linking Madras and Kuala Lumpur, covering a distance of 2509 km. The India-UAE link is the second submarine cable of the country.

The signals in the submarine cables have to be amplified at regular intervals and this is achieved by providing submerged repeaters at suitable intervals. The nominal repeater spacing for India-UAE cable is 13.5 km. The cable contains 147 repeaters each giving a gain of 48 dBs. Each repeater boosts the received power by 60,000 times or in other words the journey of a speech from Bombay to UAE is enhanced by 8.82 million times.

A big ship, specially built for cable laying, called "Venture" was used for deep waters and a small cable

ship "Galaxie" was used near the shore. When the cable was brought to the shore near Bombay with the help of a rope tied to a boat, it was kept floating by means of inflated balloons. The submarine cable was joined to the land cable in Bombay Back Bay. After the joint was accomplished the balloons were deflated and the cable slowly sunk to the sea bed.

Though the first under water cables for telephony were laid in 1891, the real long distance under water telephony began with the commissioning of the transatlantic telephone cable in 1956. The invention of insulating polyethylene and polypropylene made the cables more resistant to moisture. This ensured a life expectancy of over 25 years for the cables.

There are now 135 telephone cables on the ocean beds around the world. All of them use copper conductors in coaxial formation. The number of telephone circuits which were 36 in 1956 have now gone up to 2000. In some shorter cables, even 4,000 circuits are provided.

The real competition to submarine cables come from satellites. The present generation of satellites provide 25,000 to 40,000 circuits while the next generation, Intelsat VI, expected in 1989, will have 120,000 circuits. The cable technology still has a future as its capacity too is increasing rapidly.

UK START FOR NEW ATLANTIC LINK

Work in Britain on

laying the world's first transatlantic optical-fibre cable—code named TAT8—has started. At Wide-mouth Bay in Cornwall, the UK shore end of this £220 million undersea system is being installed by staff from British Telecom International.

The shore end of the cable will be floated ashore from a cables ship secured, and sunk into position by divers. The cables ship will then move off to lay the remainder of the first 12 km of the UK section of the cable.

Next spring, the main 520 km UK section of TAT8 will be laid by BTI's cables ship *CS Alert*. She will carry out the laying with the aid of BTI's remotely-controlled plough, which will bury the cable beneath the seabed to protect it from damage by ships' anchors and trawling.

The UK section of the cable will be connected by a further 20 km link to a special junction device on the ocean floor, 540 km south of Widemouth Bay. This will join the UK cable to a similar section from France, connecting both to the main 5,000 km span of the cable to the USA.

When TAT8 comes into service next summer, it will have the potential capacity to carry the equivalent of 40,000 simultaneous telephone calls, or their equivalent in data, text, facsimile, graphics, or TV pictures.

TAT8 is the eighth telephone cable to span the Atlantic between Europe and the United States. Its capacity is three times greater than that of all the others

together.

The new cable will form an important part of a new global communications network, which will offer customers faster connections, and improved quality links at lower cost. A whole range of additional services will be made possible with the new digital links.

A second transatlantic optical fibre cable is being planned to come into service in 1991. Called TAT9, the \$400 million system will have landing points in Britain, France, Spain, Canada, and the United States. The cable's main transatlantic section will have the capacity to carry 75,000 simultaneous phone calls.

The new cables will help British Telecom to meet the continuing growth of the number of transatlantic phone calls, which has been doubling every five years.

MERCURY SERVICE THROUGH VANDERHOFF

Mercury Communications Ltd, a wholly owned

subsidiary of Cable & Wireless PLC, has appointed Vanderhoff Business Systems to be the first distributor for the Mercury 2200 telephone service. This uses a Smart Box to connect customers to the Mercury network.

The Mercury Smart Box is installed on the exchange side of customers' PABX equipment. Its purpose is to work to the customer's advantage in deciding when a call can be more economically handled by Mercury and automatically routing it accordingly. Mercury 2200 customers benefit from call cost savings of an average of 15% on long-distance connections and itemized billing at no extra charge.

In addition to the Mercury Smart Box, Vanderhoff are also national distributors for Mercury Paging and are undertaking the billing of air time to subscribers.

Further information from **Vanderhoff Business systems Ltd • 19 Station Approach • FLEET GU13 8QY.**



LOGARITHMIC LCD VU METER

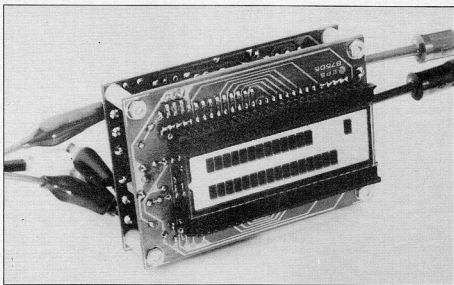

A compact, versatile AF signal level indication unit with a dynamic range of 60 dB, a dot or bar graph read-out, and a peak hold function.

Not so long ago, coloured LED bars were welcomed as the more robust and faster replacement for moving coil meters in VU (volume unit) indication units. An additional, important, advantage of the LED VU meter was that it enabled realizing the *peak hold* function, which is useful, if not indispensable, for determining the recording level on tapes. The major drawback of the LED based VU meter is its relatively high current consumption, which poses considerable problems in portable equipment. The VU meter described here is based on a liquid crystal display (LCD) with modest power requirements. The read-out is logarithmic with a scale of 60 dB, which is adequate for the dynamic range of, for instance, a CD player. The built-in peak hold function has an option for automatic reset after approximately 2 seconds. Wire links or jumpers make it possible to select dot or bar indication, but it should be noted that the peak hold function operates in the bar mode only.

The proposed LCD VU meter is composed of 2 units, namely a logarithmic amplifier and a linear LC display driver. The printed circuit boards for these have the same size to enable

building a compact indication unit using a sandwich construction—see the introductory photograph and Fig. 1. The amplifier board holds 2 logarithmic amplifiers for stereo applications. Both the amplifier and the display board can, of course, also work as a separate module in applications other than that described here: the amplifier, for instance, is also suitable for driving a moving coil VU meter, which is arranged to display a linear dB scale. Similarly, the LC display board may be used as an indication unit in, say, an electronic thermometer.

The linear LC display

The circuit diagram of this part of the VU meter is given in Fig. 2. It would have been possible to use a single display driver chip with a suitable multiplexing circuit for the LCD, but this would have been at the expense of the peak hold function. The inputs of the relatively expensive driver ICs are protected against overvoltages by networks D₁-D₂-R₃ and D₃-D₄-R₄. Selection between the various available display modes is accomplished with the aid of wire links, jumpers or a switch as summarized in Table 1. The LCD board has only 4 inputs,

which are readily connected to the respective points on the amplifier board—Fig. 3 shows the completed sandwich construction. The linear scale of the LCD gives a read-out which is directly proportional to the input voltages applied to points L and R, varying between the voltage on the respective REF LO and REF HI input (0.5 and 4.5 V). The level of the supply voltage applied to the LCD board is governed by the maximum permissible supply for the LC display (6 V), and the minimum supply level for correct operation of the driver chips (5 V).

Table 1

I ₁	I ₂	I ₃	DISPLAY MODE
L	L	X	dot mode; 18 steps
L	H	X	dot mode; 9 steps
H	L	X	bar mode; no peak value
H	H	L	bar mode; peak value, automatic reset
H	H	H	bar mode; peak value, reset: I ₂ =low
H = no wire link			
L = wire link fitted			
X = immaterial			

The logarithmic amplifier

Figure 4 shows the circuit diagram of 1 of 2 identical logarithmic amplifiers, and the power supply for the VU meter. Opamp A₁ raises the input signal and feeds this to a peak rectifier circuit. The logarithmic amplifier, composed of A₂, A₃ and matched transistors T₂ and T₃, is driven with U_{CE2}, which is directly related to the amplitude of the input signal. The matched transistors are housed in an IC type CA3046,

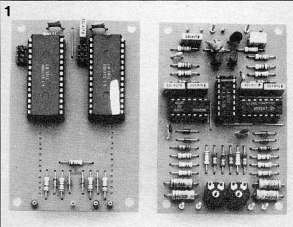

Fig. 1 The completed display driver board (l) and the logarithmic amplifier board (r) have the same size.

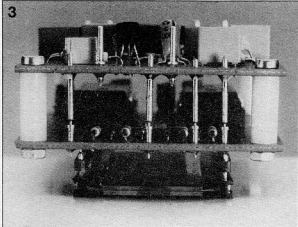

Fig. 3 The two boards can be fitted in a sandwich construction to make the VU meter as compact as possible.

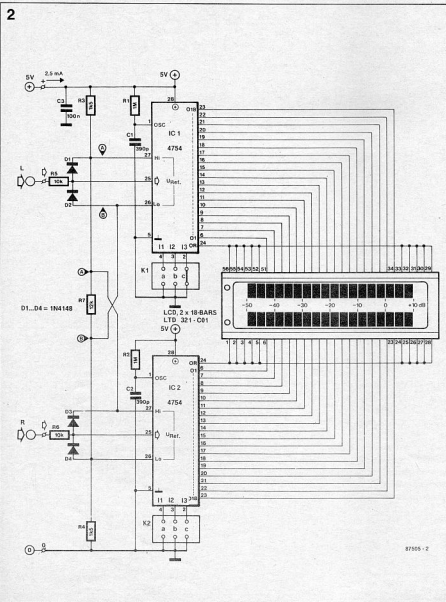

Fig. 2 Circuit diagram of the linear LCD driver.

the 4 opamps in an IC Type LM324.

The linear variation of the rectified input voltage is converted to logarithmic by means of an opamp with a feedback circuit that comprises a conventional bipolar transistor. Under certain conditions, the collector current of a bipolar transistor rises exponentially with the base-emitter voltage. Figure 5 shows how this phenomenon is exploited: the transistor forms the resistance in the negative feedback circuit of an opamp, which thus functions as an amplifier that translates its linear input signal into a logarithmic output.

The voltage transfer of this circuit is written as

$$U_o = -\frac{kT}{q} \log_e \frac{U_i}{\alpha I_o R} \quad [1]$$

in which α is the current amplification of transistor T, and kT/q at room temperature works out at about 26×10^{-3} . The weak point of this circuit is that the term I_o is strongly temperature dependent. Figure 6 shows a slightly more complex circuit whose voltage transfer is less affected by temperature variations. The voltage transfer of this circuit is

$$U_o = -\frac{(R_s + R_{10})kT}{R} \log_e \frac{U_i R}{U_{ref} R_s} \quad [2]$$

The factor kT/q is the same as in equation [1], while αI_o has been eliminated, ensuring reasonable temperature stability. Compensation of kT/q was found unnecessary for the given application, since it proved to have little effect on

the relatively low resolution of the LCD. Returning to the circuit diagram of Fig. 4, operational amplifier A_1 inverts the logarithmic voltage, so that the LC drivers receive a signal with the correct polarity.

The resolution of the display is fairly low at 18 bars. The logarithmic amplifier is dimensioned such that a variation of the input voltage of 3 decades results in an output voltage variation of 0.5 to 4.5 V. This corresponds to 1.33 V per decade. The full range then corresponds to a scale of 60 dB (-50...+10 dB) as shown in Table 2 and Fig. 7. Considering that 0 dB = 775 mV on C_5 , a dynamic range of 60 dB means that the minimum voltage for illumination of the lowest bar is 2.45 mV, which is about equal to the offset of the input voltage. It should be noted that the value of 775 mV on C_5 is not related to the definition of 0 dB as 1 mW (775 mV_{rms}) in a load of 600 Ω . The drive margin of the logarithmic amplifier is ensured by feeding it from the input voltage for the 5 V regulator, IC3. Resistors R_7 and R_8 are dimensioned such that the output voltage of A_4 can not rise above the supply level of the LCD board.

Construction and setting up

The components are fitted as per the directions in the parts list and Figs. 8 & 9. The LCD used is the type LTD-321-C01 from Mullard/Videlec. The outer 2 bars of each row of 20 on this LCD are not used in the present application. The virtually symmetrical pinning of the display, in combination with the layout of the printed circuit board, make it possible to fit the display upside down also. The contrast of the LCD is maximum when this is viewed straight, or from one side. The display is fitted either normally or reversed—but always at the copper side—depending on whether it is to be viewed from above or below. It is recommended to use terminal strips for mounting the LCD. Take note of the position indicator, which is at the left side of the LCD when this is viewed in the normal position, i.e., facing straight or from below. The PCB should be held such that the EPS number is always upside down. In the nor-

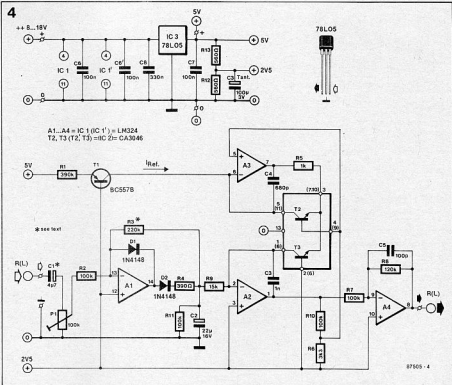

Fig. 4 Circuit diagram of the power supply and 1 of 2 identical logarithmic amplifier channels.

Table 2

Indication [dB]	$U_{(C_2)}$ [mV]	U_0 (A_4) [V]
+10	2450	4.5
0	775	3.83
-10	245	3.17
-20	77.5	2.5
-30	24.5	1.83
-40	7.75	1.17
-50	2.45	0.5

mal position, the display (2×26 pins) is fitted as far as possible to the right-hand end of the terminal strips (2×28 pins). In the reversed position, the PCB is still held as stated before. However, the position indicator on the LCD is then at the right, and the LCD itself is fitted as far as possible to the left-hand end of the terminal strips.

Preset P_1 is adjusted such that 0 dB corresponds to a direct voltage of 775 mV on junction R_4 - R_5 . This results in 3.83 V at the output of the logarithmic amplifier, and illumination of 15 bars on the LCD. A different dB scale can be set up by re-dimensioning of R_5 ... R_{10} inclusive. If the input signal has a DC component, blocking capacitor C_1

5

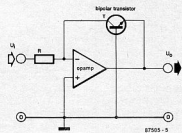

Fig. 5 The most rudimentary form of the logarithmic amplifier.

6

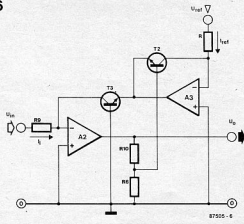

Fig. 6 This circuit is derived from that in Fig. 5, but is less affected by temperature variations.

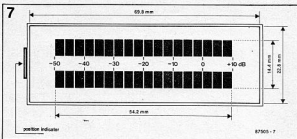

Fig. 7 Showing the position of the dB values on the face of the LC display.

is fitted with the corresponding polarity. The reset period of the peak detector is the product of R_{11} and C_2 . This period can be kept relatively short thanks to the fact that peaks in the input signal are already retained and displayed with the aid of the peak hold function. The input signal level can be adjusted with P_1 . If necessary, A_1 can be dimensioned for a higher amplification by increasing the value of R_3 . TW

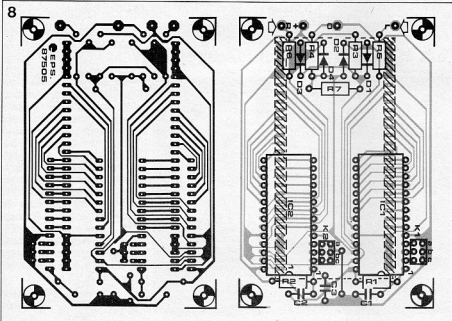

Fig. 8 Track layout and component overlay of the LCD board (circuit diagram: Fig. 2). The LCD is fitted at the track side.

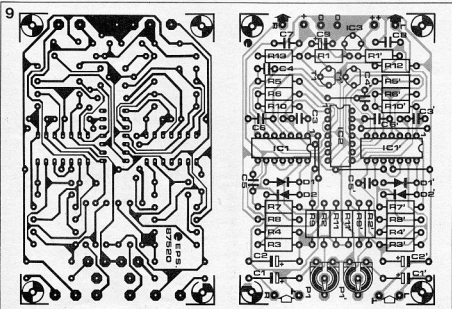

Fig. 9 Track layout and component overlay of the stereo logarithmic amplifier board (circuit diagram: Fig. 4).

Parts list

DISPLAY BOARD (FIG. 8):

Resistors ($\pm 5\%$):

$R_1, R_2 = 1M\Omega$
 $R_3, R_4 = 1K\Omega$
 $R_5, R_6 = 10K$
 $R_7 = 12K$

Capacitors:

$C_1, C_2 = 390p$
 $C_3 = 100n$

Semiconductors:

$D_1 \dots D_4 \text{ incl.} = 1N4148$
 $IC_1, IC_2 = HEF4754$

Miscellaneous:

LCD = LTD - 321 - C01
 (Mullard/Vidalec; for distributors see Infocad 507 in the April 1987 issue).
 K_1, K_2 = jumpers or terminal strips; 2 x 3 contacts.
 PCB Type 87505 (available through the Readers Services).

Available from Universal Semiconductor Devices Limited
 ● 17 Granville Court ●
 Granville Road ● Hornsey ●
 London N4 4EP. Telephone:
 (01 384) 9420. Telex: 25157
 usdco g. Fax: 01 348 9425.

STEREO LOGARITHMIC PREAMPLIFIER (FIG. 9):

Resistors ($\pm 5\%$):

$R_1, R_1' = 390K$
 $R_2, R_2', R_7, R_7', R_{10}, R_{10}'$
 $R_{11}, R_{11}' = 100K$
 $R_3, R_3' = 220K$
 $R_4, R_4' = 390R$
 $R_5, R_5' = 1K\Omega$
 $R_6, R_6' = 3K\Omega$
 $R_8, R_8' = 120K$
 $R_9, R_9' = 15K$
 $R_{12}, R_{13} = 560R$
 $P_1, P_1' = 100K$ preset

Capacitors:

$C_1, C_1' = 4\mu 7; 16V$
 $C_2, C_2' = 22\mu; 16V$
 $C_3, C_3' = 1n\Omega$
 $C_4, C_4' = 680p$
 $C_5, C_5' = 100p$
 $C_6, C_6'; C_7 = 100n$
 $C_8 = 330n$
 $C_9 = 100\mu; 3V$; tantalum bead

Semiconductors:

$D_1, D_1'; D_2, D_2' = 1N4148$
 $T_1, T_1' = BC557B$
 $IC_1, IC_1' = LM324$
 $IC_2 = CA3046$
 $IC_3 = 78L05$

Miscellaneous:

PCB Type 87520 (available through the Readers Services).

TEST & MEASURING EQUIPMENT

The field of electronic test and measuring equipment is large and still growing. Although not so long ago even an electronics engineer could get by with a multimeter, an oscilloscope, and a signal generator, nowadays even a small laboratory or workshop is equipped with an array of general purpose instruments, such as multimeters and power meters, various signal generators, a frequency counter, distortion meter, wave or spectrum analyser, and one or two oscilloscopes. In many cases, this is complemented by an LCR meter, Q meter, waveform recorder, a storage oscilloscope, and others.

To help readers find their way in this sometimes bewildering variety of equipment, we start this month a regular series of reviews of such equipment. Since the oscilloscope, after the multimeter, is probably the most frequently used instrument in an electronics environment, the series is started with a review of a number of dual-trace oscilloscopes.

The author of the series is Julian Nolan.

Part 1: dual-trace oscilloscopes (A)

Hitachi V-212

Hitachi is a Japanese company which is perhaps best known for its consumer products, especially in the video and hi-fi fields. The V-212 is one of a comprehensive range of oscilloscopes manufactured by the company, covering from the V-058G, a dual trace 5 MHz ultra compact scope, to units such as the VC-6155, a 100 MHz DSO. The V-212, which can be purchased for £320+VAT, is the dual trace version of the cheaper V-211. The accessories available include carrying cases, rack mounting kits, and viewing hoods. High-quality probes are also available, but at

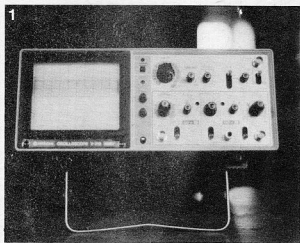

Fig. 1. Hitachi Type V212 oscilloscope

£27.50 each ($\times 10/\times 1$) it is well worth considering alternatives such as the Coline range of modular probes, which start at £13.66 ($\times 1$); the switchable $\times 1/\times 10$ version costs £17.84. High voltages, $\times 10$ probes have to be used, especially in the dual trace mode to prevent over-scanning of the trace. Although not restricting the versatility of the instrument, it can cause a small amount of inconvenience; a 20 V/div range as fitted to many instruments would have helped solve this problem. A $\times 5$ magnifier control extends the range of the Y-amplifiers to 1 mV/div, and, in the packaging of the V-212 takes into account the instru-

Table 1. Specification

ELECTRICAL CHARACTERISTICS: — Protection class 1.

Line voltage: — 110, 120, 220, 240 VAC $\pm 10\%$, Externally adjustable. Power 30 Watts. Line frequency 50, 60, 400 Hz

MECHANICAL CONSTRUCTION

Dimensions: — W 310 mm, H 130 mm, D 370 mm

Housing: — aluminium sheet

Weight: — approx. 6.5 kg

Y AMPLIFIER ETC.

Operating modes: —

CH 1 alone.

CH 2 alone or inverted

alternate or chopped (250 kHz) CH 1/CH 2.

CH 1 + CH 2.

Frequency range 0...20 MHz (-3 dB). Decreases to 7 MHz at 1 mV.

Risetime ≤ 17.5 nsec.

Deflection factor 10 steps: 5 mV/div...5 V/div $\pm 3\%$ extends

to 1 mV/div; by $\times 5$ control, increases error by 2%. Min sensitivity 12.5 V/div; variable control; fully anti cw.

Input coupling AC, DC or Gnd.

Input impedance 1 M Ω /25 pF; Max input voltage 300 V (peak

including DC voltage), or 500 Vp-p AC at 1 kHz or less.

X-Y MODE

CH 1 X-axis, CH 2 Y-axis. X Bandwidth DC to at least 500 kHz.

Less than 3° phase shift at 50 kHz.

TIMEBASE

Deflection factor 0.2 μ sec/div...0.2 sec/div $\pm 3\%$ with 1/2/5 divisions.

Expansion $\times 10$, extends max. timebase speed to 20 nsec/div;

expansion error $\leq \pm 2\%$ extra.

Uncalibrated control full cw extends range to 0.5 sec/div.

TRIGGERING

Trigger modes: — Auto (bright line), Normal, active TV (line and frame) sync.

Trigger coupling: — AC only.

Trigger sources: — CH 1, CH 2, Alternate Line, Ext.

Triggering slope: — positive or negative, switchable.

Triggering sensitivity: — Internal ≤ 1.5 div at 20 MHz, External ≤ 800 mV at 20 MHz, Normal mode.

MISCELLANEOUS

CRT-make Toshiba, measuring screen 100 \times 80 mm,

accelerating voltage 2 kV; beam rotation by front panel

adjustment.

Compensation signal for divider probe; amplitude approx.

0.5 V_{pp} ($\pm 3\%$), frequency 1 kHz.

Z modulation 5 Vp-p noticeable modulation; Max input voltage

30 V (DC + peak AC).

CH 1 output at least 20 mV/div to 5 MHz.

Covered by 2 year warranty.

ment's very compact design, and the cardboard box in which it is packed is, therefore, not much bigger than the instrument itself, which is held securely in place with polystyrene cutouts. On inspection, the Hitachi turned out to be a relatively small at 310 mm (W) x 130 mm (H) x 370 mm (D); the absence of the normal swivel stand adds to its compactness. A small one-position stand is fitted to the underside of the instrument to facilitate tilting, and for those who require the scope to be easily portable there is a carrying strap on one of the sidepanels. One advantage of the small stand is that it can easily be tucked under the scope, thus making the stacking of other pieces of equipment above or below the scope possible. The V-212 is supplied with a good length of mains lead, connecting to the scope via a standard IEC socket. Power consumption is low: only 30 W at 240 V. Unusually, the scope is also equipped with a vertical signal out BNC socket, which provides at least 20 mV/div into 50 Ω .

The specifications are shown in Table 1. From these it can be seen that the maximum Y amplifier sensitivity is an excellent 1 mV/div, while the minimum is 5 V/div (calibrated) or approx. 12.5 V division (uncalibrated). When measuring relatively dead, increases the versatility of the Y-amplifiers throughout the range, providing a calibrated step outside the standard 1-2-5 sequence, i.e., in a 2-4-10 sequence. This does however introduce a $\pm 2\%$ increase in Y amp error, bringing the total to a maximum of $\pm 5\%$. Putting this into perspective in relation to, say, a waveform of typical total deflection of 40 mm, it may be that with even a $\pm 5\%$ Y amp error, a total deflection error of more than ± 2 mm is unlikely to be generated. In the $\times 5$ mode, however, the Y amps are limited in bandwidth to 7 MHz (-3 dB). On the whole I did not find this restriction limiting as the full bandwidth is still usable at 5 mV, at which sensitivity the Y amps performed very well at their maximum bandwidth, being well inside their -3 dB specified limit. The input amps also exhibited practically zero drift during their warm up



Fig. 2. Close-up of V212 controls

Table 2.

CATEGORY	Unsatisfactory	Satisfactory	Good	Very Good	Excellent
TRIGGER FACILITIES					
TRIGGER PERFORMANCE				x	
CRT BRIGHTNESS				x	
CRT FOCUSING					x
Y AMP PERFORMANCE				x	
INTERNAL CONSTRUCTION					
EXTERNAL CONSTRUCTION					
OVERALL SPECIFICATION					x
EASE OF USE				x	
MANUAL					
X/Y PERFORMANCE					

TABLE EXPLANATION

TRIGGER FACILITIES—The triggering facilities offered by the scope, eg alternate triggering, TV sync, auto trigger, etc.

TRIGGER PERFORMANCE—Is an indication of how well and easily the scope triggers on a wide variety of waveforms, as well the maximum triggering frequency.

CRT BRIGHTNESS—This is an indication of the brightness available on a fully triggered waveform at the maximum deflection speed. Note: some scopes have internal brightness presets, setting the maximum and minimum brightness; this is not taken into account.

CRT FOCUSING—The standard of the focusing over the whole range of deflection speeds and display modes.

Y-AMP PERFORMANCE—An indication of the maximum sensitivity of the Y-amp, along with its performance across the bandwidth.

INTERNAL CONSTRUCTION—This rating assesses the scope's internal construction, the main criterion being the quality of the PCBs and other components, the general neatness and layout with a view to servicing and the mechanical robustness.

EXTERNAL CONSTRUCTION—The strength and quality of the materials used, along with the finish are among the criteria here.

OVERALL SPECIFICATION—This takes into account other features which may be provided on the scope, such as trigger hold-off or a third channel, as well the general specification of the scope.

EASE OF USE—This assesses the general layout of the controls, and ease of use for a first time user, and not the ease of operation of the range switches etc.

MANUAL—Takes into account the actual information included in the manual which is likely to be useful to the user.

period making instant measurements easier.

The vertical modes of the V-212 are fairly standard, including alternate and chopped (250 kHz) modes for dual trace operation. Only one channel (2) of the V-212 is invertible for subtraction purposes, this being implemented, as are some of the other functions, by pulling an associated control (in this case CH 2 position) to its out position. This does have advantages in that it helps provide an uncluttered layout, but it also means that when this 'secondary' function is operated, it is very easy to offset the 'primary' function from its original value.

Triggering on the Hitachi is of a very high standard, incorporating the unusual feature of an alternate channel triggering mode. This permits stable, fully triggered traces to be produced in either dual trace mode from two non-synchronized sources, as each channel is triggered independently. This is invaluable for taking measurements where more than one signal source is being used within a circuit, and is also helpful for single trace measurements, enabling the stable display of either channel without having to manually alter the triggering channel. Active TV frame and line triggering are also provided on the V-212, making triggering on video signals an easy task. The performance of this was good, triggering even at very low levels and over an acceptable range of line and frame frequencies. Two notable exceptions from the V-212's triggering facilities are HF and LF coupling, and although it is possible to get around this problem when these functions would normally be required by fine adjustment of the triggering threshold, the necessary filters would have made operation easier. Selection of the triggering criteria is made by a number of lever operated switches, making for fast, reliable and convenient operation of the scope. Trigger sensitivity was satisfactory at 5 mV internally and 200 mV externally in the 20 Hz to 2 MHz range, increasing to 10 mV internally and 800 mV externally in the 2 MHz to 20 MHz range. Generally the triggering performance was very good, with the alternate triggering being a particular bonus; this is not

mally only found on models outside this price range. A stable trace was produced in nearly all cases; the trigger threshold control did, however, prove to be sensitive and it was very easy when pulling this control out (for triggering on the trailing edge of a signal) to offset it outside the triggering threshold, thus causing the timebase to free run, producing an unlocked trace.

Maximum timebase speed is 200 ns/div; this is however extendable to a maximum deflection speed of 20 ns/div (not 100 ns/div as stated in the manual) by means of a $\times 10$ control, although naturally this is at the expense of trace intensity. Speed selection is by means of a 19-position rotary switch, the minimum speeds being 0.2 s/div (calibrated) or roughly 0.5 s/div (uncalibrated). On the maximum deflection speed of 20 ns slight defocusing occurs towards the end of the trace, which is unfortunate, because for the remaining speeds focusing from the Toshiba tube is excellent for a 2 kV acceleration voltage. Despite this, the performance of the scope in this area is particularly good, many of its rivals not offering a 20 ns/div sweep speed, although, as I have said, accurate measuring over the last third of the trace at this speed is limited by the 2 mm wide trace over this area. The screen itself is filtered a light blue and has full graduations for risetime measurement. The V-212 is equipped with Z-modulation and CH 1 vertical signal out facilities; the BNC connectors for both these functions are mounted on the back panel. For noticeable intensity modulation a 5 V p-p signal is required, the input bandwidth for this function going up to 2 MHz. The CH 1 output on the other hand provides a buffered output from channel 1 which could be used to drive, for example, a counter/timer, thus providing an accurate readout of frequency, etc.

Aluminium plays an important part in the V-212's construction, both the outer housing and frame are manufactured from this, which contributes to the scope's light weight of 6.5 kg. Plastic is used for the front fascia surround, and this could prove to be fragile, especially around the top corners if the scope is used in rugged con-

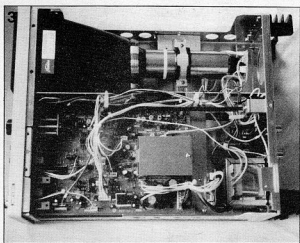

Fig. 3. Internal view of V212

ditions. Robust feet/cable holders are featured on the rear panel and protect the instrument to a large extent from any damage which may occur if, for example, the instrument is dropped while being carried. In contrast to many other scopes, all the controls have a very positive and fairly light action, making for easier, more precise operation. Some, however, notably the Y amplifier fine controls, protrude a good distance from the front panel, making accidental damage more likely in the event of a fall. My only major criticism of the Hitachi, if it can be called that, is the internal construction. The main circuitry is mounted on two PCB's of equal size, but larger components, such as voltage regulators, etc., are mounted on the chassis itself for good heat dissipation. This wide variety of mounting points coupled with the three remaining PCB's housing the tube base, etc., necessitates the use of a large number of wire connections and links, giving the inside of the Hitachi an appearance not dissimilar to one of the company's tapes. All of the interconnections appear to be of a very high quality, however, and I have been assured by Hitachi that the number of interconnections in no way affects the reliability of the scope. This is proved by the fact that Hitachi oscilloscopes using the same construction technique are offered for hire by some of the electronic equipment rental companies, where reliability is obviously at a premium. Ignoring the number of interconnections, internal construc-

tion was generally good; the large number of connections making the mounting of all high power dissipation components on the subframe possible. The internal construction itself is extremely compact: the two main PCBs are mounted horizontally above one another at the front of the instrument. Unlike the Y amplifiers, the EHT section of the circuit is completely shrouded, thus helping to prevent the build up of dust, as well as helping to prevent any

possible shock should be outer housing be removed.

Not surprisingly, most of the semiconductors are manufactured by Hitachi themselves; other components come from a variety of manufacturers and are fairly standard, ranging from miniature resistors to the industry standard 78 and 79 series monolithic fixed voltage regulators.

The 56 page manual contains a number of detailed sections, among which how to set up to scope initially, and a particularly good section on measuring procedures. There are no sections on calibration or servicing, and the roughly A5 size of the manual makes the circuit diagrams small and in place difficult to understand as they are spread out over a number of pages. There is also no circuit description. Overall, although containing some good sections, the manual missed out on several important points and could have been accurately summarized in a considerably shorter space.

Conclusion

The Hitachi V-212 is generally a

Other Hitachi scopes under £1000

20 MHz

V-222: As V-212 plus alternate magnify, swivel stand, scale illumination, uncal. indicators. Probes are also included. £395 + VAT.

V-223: As V-222 plus sweep delay, 1 μ sec to 100 msec. £450 + VAT.

V-225: As V-223 plus on-screen cursor measurement of voltage and time difference. £550 + VAT.

40 MHz

V-422: As V-222 plus signal delay line, 12 kV accelerating voltage. £580 + VAT.

V-423 and V-425: As V-223 and V-225 respectively, but with increased bandwidth. V-423: £650; V-425: £695.

60 MHz

V-650F: Similar to V-422 + dual timebase, trigger view, delay multiplier: £780 + VAT.

PORTABLE

V-209: 1 mV sensitivity 3.5" tube, lightweight miniature format, battery/mains, NiCd batteries included: £680 + VAT.

well-thought out scope, with some advanced features, and is competitively priced at £320 + VAT. Triggering is particularly good, having an alternate triggering facility and this coupled with the scope's excellent CRT, which is one of the best 2 kV tubes I have seen, make it well worth looking at.

The scope's small size also makes it eminently suitable for those users who include portability high on their list of priorities. It does have one or two minor shortcomings, such as its internal construction, which, although of a fairly high standard, does possess a large number of interconnecting

wires, which could make servicing difficult. However, I am quite happy that they will in no way affect reliability. The manual is not really up to standard, despite its length, providing only the initial 'set up' information, which admittedly is good. Summing up, the V-212 should represent a good choice

for most users who need a flexible scope for a wide variety of tasks.

The Hitachi V-212 was supplied by Hitachi-Denshi (U.K.) Ltd • 13-14 Garrick Industrial Centre • Garrick Road • Hendon • London NW9 9AP.

Crotech 3133

The company of Crotech was formed in 1981, and now designs a wide range of test equipment from frequency counters to signal generators. The 3133 is one of a range of six oscilloscopes manufactured by the company. The range extends from the single trace 3031 at £199 to the 3339 which features a 30 MHz bandwidth, as well as a VDU mode, enabling the scope to act as a monitor, at £570. The new 3133 is priced at a competitive £319. The 3133, which replaces the 3132, is unique in its price range in that it incorporates a component comparator and a power supply outlet in its design, and has a bandwidth of 25 MHz (-3 dB). Probes are also supplied, but these are of the 'crocodile clip' x1 design, so their usefulness for RF work is limited. A x1/x10 probe may be purchased as an optional extra, along with a light hood and trolley.

The 3133 is somewhat unusual

in its layout, with the CRT situated in the centre of the scope and the Y-amp and timebase/triggering controls positioned at either side of it. This gives the scope the average size of 330 (W) x 395 (D) mm, although the height is somewhat higher than normal at

165 mm. The weight of the 3133 is also on the somewhat heavy side at 8.5 kg. A three position swivel stand is fitted, which, given the external graticule of the tube, is just as well, since it enables the scope to be positioned to minimize the small parallax error. Mains connec-

tion is by means of a fixed lead, i.e., no socket, which is a pity, since it is of only average length so that in some cases it may be necessary to extend its length. As I have already mentioned, the 3133 incorporates some rather unusual features, these in the main being the power supply, component comparator and the more common trigger hold-off facility.

The front panel layout is fully colour coded, and this should make first time operation no problem, as well as contributing very significantly to the scope's ease of use. Most of the functions are selected by a series of push-button switches, which are arranged in four groups: CH 1 input coupling; CH 2 input coupling; Display mode; and trigger functions etc. While these provide an easily identifiable, and in some ways more flexible, method of function selection, I found that operation is perhaps slightly more time-consuming than the more usual 'slider' type switches.

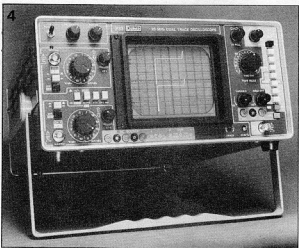

Fig. 4. The Crotech 3133 oscilloscope

Table 3. Specification

ELECTRICAL CHARACTERISTICS

Line voltage: — 115, 220, 230, 240 VAC, internally adjustable.
Power 40 Watts. Line frequency: 27-65 Hz.

MECHANICAL CONSTRUCTION

Dimensions: — W 330 mm, H 165 mm, D 395 mm
Housing: — aluminium sheet
Weight: — approx. 8.5 kg

Y AMPLIFIER ETC.

Operating modes: —
CH 1 alone.
Inversion capability on CH 2 only.
Alternate or chopped (120 kHz) CH 1/CH 2.
CH 1 + CH 2.
Frequency range 0...25 MHz (-3 dB).
Risetime \leq 14 nsec.
Deflection factor 12 steps: 2 mV/div...10 V/div \pm 3%; no variable attenuation controls.

Input coupling AC, DC or Gnd.
Input impedance 1 M Ω /25 pF; Max input voltage 400 V (DC + peak AC).

X-Y MODE

CH 1 Y-axis, CH 2 X-axis. X Bandwidth DC to 1 MHz (-3 dB).
Phase shift at 50 kHz \leq 3°.

TIMEBASE

Deflection factor 0.2 μ sec/div...0.5 sec/div \pm 3% with 1/2/5 divisions.
Expansion \times 5, extends max. timebase speed to 40 nsec/div (variable control fully anti cw), expansion error \leq 2% extra; typical variable control error \pm 2%.

TRIGGERING

Trigger modes: — Auto (bright line); Normal; active TV (line and frame) sync.
Trigger coupling: — AC, DC, HF reject.
Trigger sources: — CH 1, CH 2, Line, Ext.
Triggering slope: — positive or negative, switchable.
Triggering sensitivity: — Internal \leq 0.5 div at 25 MHz, External \leq 1 V at 25 MHz, Auto mode.

MISCELLANEOUS

CRT—make NEC, 13 cm front faced round tube (viewing area approx. 100 \times 80 mm); accelerating voltage 2 kV, beam rotation by front panel adjustment.
Compensation signal for divider probe, amplitude approx. 0.2 V_{DD} (\pm 3%), frequency 1 kHz.
Z modulation 20 Vp-p for complete blanking (—).
Power Supply: 5 V at 1 Amp, +/—12 V floating at 200 mA continuous.
Component Comparator: — test voltage 8.6 V r.m.s., test current 28 mA max; line frequency = test frequency.
Covered by 2 year 'Blue Chip' warranty.

The Y-amplifiers, which are positioned to the left of the tube, surprisingly have a bandwidth of 25 MHz: 5 MHz more than the 20 MHz offered by its direct competitors. Performance of the Y-amps is certainly good, meeting the 25 MHz bandwidth well inside its -3 dB limit. The 2 mV/div maximum Y-amp sensitivity is effective across the whole bandwidth, allowing accurate measurement of low amplitude RF signals. This range extends up to a useful 10 V/div. I found calibration accuracy on all of these ranges very good, and well within the quoted $\pm 3\%$. It is a pity, however, that both Y-amplifiers have no variable control. This among other things makes accurate risetime measurements difficult, unless the deflection amplitude of the signal matches that of the risetime graticule. Both Y-amps have a 14 ns risetime to accommodate their wider than usual bandwidth and this does, of course, help in giving more accurate high frequency pulse deflection representations than the more common 17.5 ns risetime. This reduced risetime is largely due to the use of faster FETs in the input stage and in my view is well worth the trouble, not only having the advantages outlined above, but also that at 20 MHz the attenuation is way below the -3 dB level, enabling more accurate vertical measurements to be made across the whole upper bandwidth.

The display modes on the 3133 are fairly standard, with the exception that in single trace mode only CH 1 can be displayed, instead of the more usual switchable CH 1/CH 2 option. This is certainly not a major setback, but it can entail a certain amount of lead swapping, or trace repositioning, if, for example, it is necessary to display a signal connected to CH 2 for a full 8 cm vertical deflection amplitude. A 1 kHz 200 mV ($\pm 2\%$) p-p divider probe compensation square wave output is provided.

An ever increasingly popular feature is the trigger hold-off facility, which is now finding its way into the 'under £350' price bracket. This, along with the increase in bandwidth and slimline appearance, is one of the main differences between the new 3133 and the older 3132.

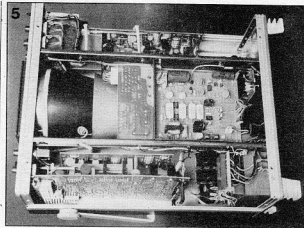

Fig. 5. Internal view of 3133 (right-hand)

Trigger hold-off facilitates stable triggering on complex and irregular waveforms, and as such is useful for displaying, for example, complex pulse trains in digital work over a wide range of timebase speeds. The 3133's hold-off facility coped with a wide variety of timebase speeds and waveforms, ranging from a simple double pulse to a complex pulse train. Other triggering functions include the more standard HF reject and TV synchronization. Triggering performance is good for the vast majority of waveforms. When the scope is in auto mode and the TV frame sync is in operation, however, it is difficult to lock on to the frame sync pulses during a steady video signal; a changing video signal with a low signal content makes this next to impossible. No problems were encountered in the line sync mode and reliable TV (both frame and line) triggering was present in Normal mode. AC and DC coupling and

Normal and Auto modes are also provided, making triggering effective across a wide range of signals. Alternate, or Vertical triggering, is not a feature of the scope, and consequently non-synchronized waveforms cannot be stably displayed on both traces. Triggering sensitivity is very good, typically being 2 mm up to 25 MHz internally, which is well inside the 0.5 div deflection quoted, or approximately 700 mVp-p externally, again well inside the quoted 1 Vp-p. To obtain these sort of sensitivities, fairly critical adjustment of the triggering threshold is, however, required, although triggering on the quoted sensitivities is more easily accomplished. Timebase speeds range from 0.2 secs/div to 0.5 μ secs/div; the maximum speed being increased to 200 nsec/div by the use of a variable control. Calibration accuracy of the timebase is $\pm 3\%$, the variable

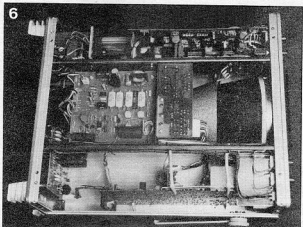

Fig. 6. Internal view of 3133 (left-hand)

control, when fully clockwise, adds about 2% to the error. A $\times 5$ control is provided, which increases the maximum deflection speed to 40 nsec/div and brings the maximum error at this speed to approximately 7%, which I found acceptable for all tests carried out on the scope. The maximum sweep speed of 40 nsec/div gives a 1 division horizontal resolution for a 25 MHz sine wave and should be enough for most purposes. The 3133 is one of the few scopes which still use an external graticule CRT. On the 3133, parallax error is kept to a minimum by sticking the graticule template directly onto the CRT, and, although a small parallax error is obviously still present, I found that the extra measuring error incurred when taking measurements is practically zero, if the screen is viewed from a constant angle. The external graticule does, however, slightly obscure the trace along its markings to a small extent, and in some circumstances it may be necessary to slightly alter the viewing angle to clearly observe the whole of a low intensity trace. The 2 kV CRT itself is round and because of this the trace cannot be observed at the corners of the viewing screen. However, under normal conditions, this in no way affects the measuring capability of the instrument, as most measurements are taken at or around the centre of the screen. It may, however, slightly affect dual trace operation, causing a small adjustment in waveform amplitude or position on, for example, a pulse wavetrain, where viewing of the initial leading edge could otherwise be partly obscured.

Automatic focusing is not incorporated, and consequently a small adjustment is necessary when, for example, changing deflection speeds from 50 msec/div to 40 nsec/div in order to maintain the optimum focus of the trace. The focusing of the CRT at low to medium intensities is quite good, although at higher intensity's slight defocussing did occur, although with the good brightness available this is not surprising. Despite this, the tube's performance on the focusing side does not quite match that given by some of the better 2 kV internal graticule, rectangular tubes. The CRT is

protected by a deep blue plastic faceplate and is mounted in a bezel which also has camera mounting cut-outs.

The cost saving on the external graticule tube allows extra features, such as the power supply, to be incorporated. This has three outputs which consist of a negative ground 5 V 1 Amp supply, suitable for driving TTL etc., and to floating ground outputs which can be configured as ± 12 V (200 mA each), ± 24 V or ± 24 V supplies, suitable for driving a whole host of devices from op-amps to CMOS logic. This facility should prove useful to most users, even those who already have their own power supplies, mainly because in contrast to the average power supply, with perhaps 1 or 2 supply rails, the 3133 has 3, already configured to supply simultaneously both analogue and digital circuitry. For those users who already have a comprehensive power supply, this feature may be of more limited use, but I feel still worth while. The component comparator consists of two component testers, which generally display a V-I type curve of the component under test. The test signal is an 8.6 V r.m.s. sine wave, which produces, for example, a sharp right angle for a typical diode, or ellipse for a capacitor. Although it does not provide any accurate information as to the component's value, it does provide a very clear indication of whether the component is operational, if it is, for example, 'leaky'. Component comparison is also possible with the 3133 two testers, enabling a known good device to be accurately compared with other examples. It is also possible to compare complete circuits with this technique, each circuit effectively having its own 'signature'. Initially, I was a little sceptical of the component tester, mainly because I was unsure if its usefulness, in view of the fact that the vast majority of scope users possess a multimeter. This opinion was, however, quickly changed by the component tester, which proved to provide a quick and very clear method of both testing and comparing compo-

Table 4.

CATEGORY	Unsat- isfactory	Satisf- actory	Good	Very Good	Excellent
TRIGGER FACILITIES					
TRIGGER PERFORMANCE				x	
CRT BRIGHTNESS			x		
CRT FOCUSING			x		
Y AMP PERFORMANCE				x	
INTERNAL CONSTRUCTION				x	
EXTERNAL CONSTRUCTION					x
OVERALL SPECIFICATION				x	
EASE OF USE				x	
MANUAL				x	
X-Y PERFORMANCE				x	

nents, allowing the user in most cases to see their actual characteristics.

Both the internal and external construction are of a very high standard. Internal construction is based around a relatively large number of PCBs, totalling seven in all. The timebase, Y-amplifiers, power supply, etc., are all mounted on different boards, thus making servicing greatly easier. All the PCBs are silk screened with the various component identification numbers, and, where appropriate, their function. Both the attenuator stage in the Y-amplifiers and the EHT section are fully shrouded, as is the CRT. The components themselves come from a wide variety of sources and all appear to be of a good quality. All internal wiring is neatly grouped, giving the inside of the scope a very neat appearance. External construction of the scope is to the same high standard, being almost completely aluminium. This also includes, unusually, the front panel, which is silk screened with the appropriate markings. None of the front panel controls extends beyond the display bezel, which further increases the robustness of the scope. With the construction in mind, it is not surprising to learn that among the users of the 3133's predecessor, the 3132, are British Nuclear Fuels, GEC, UKAEA and several large industrial companies.

A comprehensive manual and a book entitled *Getting The Best From Your Scope* are included with the 3133. Both are very good, the manual covering initial setting up, servicing and calibration, while the book deals with a wide range of applications, including TV servicing. The manual also includes a

full circuit diagram, as well as diagrams of both mechanical construction and PCB layout.

Conclusion

The Crotech 3133's extra functions and higher than normal bandwidth turn what otherwise would perhaps be an unexceptional scope into one which is well worth looking at, especially when the price of £319 is taken into account. While the CRT gives a reasonable performance, its external graticule can make accurate measurements slightly more time consuming. It is probable, however, that the extra bandwidth and functions offered by the 3133 over its rivals will be worth this to the many users who require a scope which can be used for a large number of applications. The high standard of construction is also one of the 3133's assets. The 3133 is particularly suited to new users of scopes, as it is particularly easy to operate and it is supplied with two good manuals. To sum up, the 3133 certainly represents value for money, offering as it does a number of useful extra functions and a reasonable performance, while maintaining a very high standard of construction. If you require a versatile scope, with a wide range of features along with good construction quality, I can certainly recommend it.

I have been informed by Crotech that they intend to improve the TV triggering performance of the 3133; the review model was a pre-production prototype.

The Crotech 3133 was supplied by Crotech Instruments Ltd., 2, Stephenson Road, St. Ives, Huntington, Cambridgeshire PE17 4WJ. Tel. (0480) 301818

Other Crotech scopes

DUAL TRACE

3132—Preceding model to 3133, main differences 20 MHz bandwidth, no trigger hold-off, design. Currently £285 + VAT.

3337—30 MHz version of 3132, main differences 10 kV acceleration voltage, no component tester, signal delay. Currently £425 + VAT.

3339—Same as 3337, except VDU mode facility and the addition of a component tester and power supply. Currently £570 + VAT.

SINGLE TRACE

3031 and 3032—single trace, 20 MHz, component tester, 3031 9.5 cm rectangular tube, 3036 13 cm round tube. Currently £199 and £220 respectively (both + VAT).

Next month, Julian Nolan reviews the Gould OS300 and the Grundig MO20 oscilloscopes.

PHILOSOPHIAE NATURALIS PRINCIPIA MATHEMATICA

or

MATHEMATICAL PRINCIPLES OF NATURAL PHILOSOPHY

by

ISAAC NEWTON

1687 — A TERCENTENARY CELEBRATION — 1987

by Dr. T.R. Carson, University of St. Andrews, Department of Physics & Astronomy.

Isaac Newton was born on 25 December 1642 in the manor-house at Woolsthorpe, near Grantham, Lincolnshire. He died on 20 March 1727 at Kensington, London and was buried in Westminster Abbey. Thus he lived under seven monarchs, as well as two protectors, in what can surely be described as an age of revolution. Against this politically turbulent background the world of learning was undergoing, after a similarly turbulent start, its own albeit quieter evolution. The ancient philosophy of Aristotle, despite the efforts of Aquinas, had already sunk into decline. Of the three Philosophies, Metaphysical, Moral and Natural, the latter was poised for its most dramatic development. Man's place in the physical universe had been redefined by Copernicus and Bruno. Bacon and Galileo had initiated a new science, based on observation and mathematically precise description, so immediately exemplified in Kepler's three laws of planetary motion. The most influential philosopher of the seventeenth century was Descartes, whose attempt to construct an all-embracing philosophy of the world, failed even to resolve his own conflict between reason and authority. Nevertheless it had a lasting impact on the

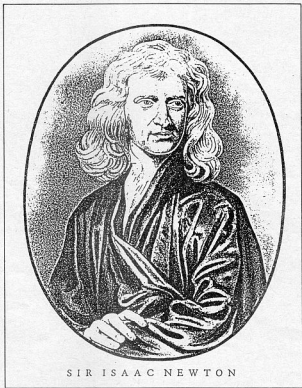

future development of natural philosophy through its reduction of all reality to matter and motion. Newton's 'Principia' represented the next step along this road. Matter was invested with certain intrinsic properties, both active and passive, while motion became a

series of events in space and time subject to quantitative analysis based on premises of cause and effect. Later on the combination of Descartes' analytical geometry and Newton's differential and integral calculus would become powerful tools in forging a com-

plete mechanistic philosophy. Due to the death of his father two months before his birth, Newton spent his early years with his maternal grandmother in Woolsthorpe. In 1654 he entered the grammar school in Grantham, but left in 1656 to help manage the family farm, returning to school in 1660 to prepare for college for he showed a remarkable precocity in mathematics. In 1661 he matriculated at Trinity College, Cambridge, where he became a scholar in 1664 and graduated B.A. in 1665. He became a fellow of Trinity College in 1667 and in 1669 was elected Lucasian professor of mathematics in succession to Isaac Barrow whom he had impressed as "a very ingenious person" and "a man of exceptional ability and remarkable skill". He was elected to fellowship of the Royal Society in 1672 and represented the university in parliament in 1689 and in 1701, and was finally appointed to the post of Warden of the Mint in 1696 and Master in 1699. In 1703 Newton became president of the Royal Society, which office he retained for life. He was knighted by Queen Anne on the occasion of her visit to Cambridge in 1705. During the years 1665-1666, at a time of enforced absence from Cambridge due to the plague,

at Woolsthorpe, Newton made a number of advances in optics, mathematics, mechanics and gravity. It was mainly with the last three topics that the "Principia" would be later concerned, but it was during this rural retreat that the seeds of that bountiful harvest were sown. Newton himself wrote later "... from Kepler's rule of the periodical times of the planets [Kepler's third law] ... I deduced that the forces which keep the planets in their orbs must be reciprocally as the squares of their distances from the centres about which they revolve: and thereby compared the force requisite to keep the Moon in her orb with the force of gravity at the surface of the earth, and found them answer pretty nearly. All this was in the two plague years of 1665 and 1666 ... for in those days I was in the prime of my age for invention and minded Mathematics and Philosophy more than at any time since ... between the years 1676 and 1677 I found the proposition that by a centrifugal force reciprocally as the square of the distance a planet must revolve in an ellipse about the centre of force as focus [Kepler's first law] ... and with a radius drawn to that centre describe areas proportional to the times [Kepler's second law]". Christian Huygens had already published in 1673 the rule of centrifugal force for uniform circular motion. What Newton did was to define the concepts of quantity of motion (momentum) and force, and the laws relating to them. He also made the conceptual move from centrifugal to centripetal force and generalized from the circle to the ellipse, having already postulated the universality of the gravitational force on the falling terrestrial body and that acting on the Moon and other heavenly bodies. The story of the apple falling from the tree in the garden at Woolsthorpe was told by William Stukeley in recounting his conversations with Newton in 1726, and also by Voltaire who obtained it from Newton's step-niece. The tree was cut down in 1820 but a portion of the trunk may be seen in the library of the Royal Astronomical Society in Burlington House, Piccadilly. The events leading up to the publication of the "Principia" began with the visit to Newton

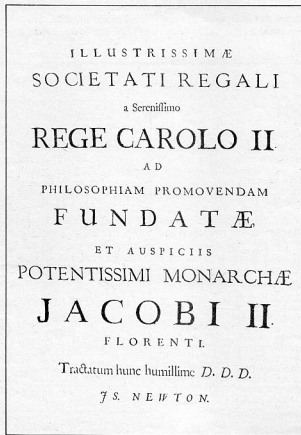
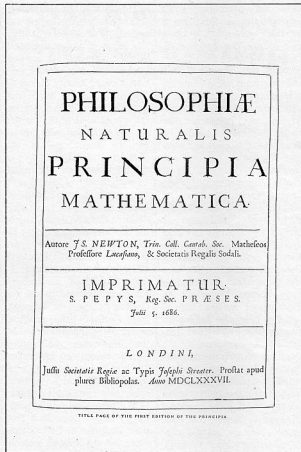

in 1684 of Edmund Halley (soon assistant secretary of the Royal Society and editor of Philosophical Transactions) to pose the question, prompted by a discussion with Robert Hooke and Christopher Wren, as to what orbit a planet would follow if attracted to the Sun by a force varying inversely as the square of the distance. Halley, impressed by Newton's immediate answer, asked for the proof, which Newton sent and was received by Halley with such great satisfaction that he visited Newton again to discuss the matter. He reported to the Royal Society the "curious treatise, De Motu (On Motion)" which Newton had promised to send to the Society. This was received in February 1685, Halley's intention being to secure the position until Newton could publish his work, as he was encouraged to do by Halley and by the Royal Society. In April 1686 the Royal Society received a manuscript, in the hand of namesake and amanuensis Humphrey Newton, of what Halley referred to as an "incomparable Treatise on Motion" entitled "Philosophiæ Naturalis Principia Mathematica" and dedicated to the Society by Newton. This was in fact the first part of the "Principia", comprising the "Definitions", "Axioms or Laws of Motion" and "Book I - On the Motion of Bodies", bearing the full title of the whole work. The Society resolved to have the manuscript printed without delay at its own expense, and furthermore entrusted Halley to supervise the printing. For financial reasons the Royal Society shortly ordered that Halley print it at his expense which he engaged to do. In June 1686 Newton informed Halley that he had intended the "Principia" to consist of three books, of which the third would concern the system of the world, which he now proposed to suppress because "Philosophy is such an impertinently litigious Lady that a man had as good be engaged in Law suits as have to do with her". Newton realized that the title of the whole work would no longer be as appropriate, considered changing it, but on second thoughts retained the former title to help the sale of the book. Halley begged Newton "not to ... deprive us of your third

book", adding that it would make the "Principia" acceptable to "those that will call themselves philosophers without mathematics, which are by far the greater number". Newton deferred to Halley and duly delivered to him "Book II — On the Motion of Bodies in Resisting Media" in March 1687 and "Book III — On the System of the World" in April 1687. On 5 July 1687 Halley wrote to Newton that he had "at length brought your book to an end, and hope it will please you". Halley had written a latin ode, dedicated to Newton, with which he prefaced the work. In his own preface Newton paid a glowing tribute to the assistance which Halley had given him. The title page bore the "imprimatur" of Samuel Pepys, President of the Royal Society. The number of copies printed is unknown but has been estimated as high as four hundred. Newton received twenty for himself and forty for disposal through booksellers. The price to the trade was six shillings in sheets, reduced to five shillings for cash, but nine shillings leatherbound and lettered!

News, emanating from Halley and John Flamsteed (first Astronomer Royal), of the impending appearance of the

"Principia" had generated much excitement. Reactions to the book were quick to follow publication. Two reviews appeared in French (Journal des Savants, Bibliotheque Universelle) the latter being attributed to John Locke, one in Latin (Acta Eruditorum), and one in English (Philosophical Transactions) by Halley. Readers were left in no doubt as to the scope and scale of Newton's achievement. Newton's work appealed particularly to mathematicians like James Gregory (St Andrews and Edinburgh) and his nephew David Gregory (Edinburgh and Oxford). Perhaps the first continental student of Newton was Nicolas Fatio de Duillier, a Genevese mathematician who was instrumental in spreading news of the "Principia" to Huygens in Holland and to Leibnitz, otherwise known for his controversy with Newton regarding the calculus, in Germany. An early casualty was Descartes's philosophy, particularly as it applied to mechanics, including his theory of vortices relating to celestial motions. However, to Newton the concept of action at a distance without mediation was an absurdity, a point of some importance when considering the later revolution due to Einstein. Newton also made it clear that while in-

volving gravity as a cause of (change of) motion, he was making no statement regarding the cause of gravity itself and permitted himself but one reference to God in the first edition. Richard Bentley, Master of Trinity College, in his Robert Boyle Lectures (1692), noted that the dispositions of the planets relative to the Sun were critical for the sustenance of life thereon, leading him to "discern the tokens of Wisdom in the placing of our Earth". George Berkeley, Bishop of Cloyne, attacked Newton's concepts of absolute space, absolute time and absolute motion as inadmissible since they entertained "something besides God which is eternal, uncreated, infinite, indivisible, unmutable". Joseph Addison too upheld the thinking of Descartes, although both Berkeley and Addison would later publish defences of the Newtonian philosophy. Leibnitz considered that gravity "without any mechanism... or by a law of God... without using any intelligible means, ... a senseless occult quality...". Roger Coates (first Plumian Professor of Astronomy), editor of the second edition (1713) of "Principia" under Bentley's supervision, advised Newton to counter the criticism of Leibnitz. For the second edi-

tion Newton thus prepared the famous General Scholium containing the sentence "... And thus much concerning God; to discuss of whom from the appearance of things, does certainly belong to Natural Philosophy...". Herein too is found the famous declaration "... hypotheses non fingo... (I frame no hypotheses)", which must be taken only in the context of the cause of gravity, for Newton framed many hypotheses. The third edition (1726) was prepared for Newton by Henry Pemberton who also, a week after Newton's death, announced a translation of the "Principia". This was never published and the first English translation was that of Andrew Motte in 1729. Fatio was the author of the epigram on Newton's tomb: "Sibi gratulentur Mortales, Tale tantumque extitisse Humani Generis Decus (Let mortals rejoice that there has existed such and so great an ornament of the human race)". Amongst the many tributes that have been accorded Newton's "magnum opus" few are as generous as that of Laplace in referring to the causes "which will always assure the "Principia" under Bentley's supervision, advised Newton to counter the criticism of Leibnitz. For the second edi-

stereo pan pot

This circuit offers the possibility of stereo image width control from stereo, through mono, to reverse stereo. The circuit comprises two emitter followers and a linear stereo potentiometer.

If x is the ratio of the resistance between the sliders of the pots and the lower ends of the pots to the total resistance then it follows that the outputs L' and R' are given by:

$$L' = R(1-x) + Lx$$

$$R' = Rx + L(1-x)$$

Therefore, when $x = 1$, $L' = L$ and $R' = R$ (normal stereo); when $x = \frac{1}{2}$, $L' = R' = \frac{1}{2}(L + R)$ (mono); when $x = 0$, $L' = R$ and $R' = L$ (reverse stereo).

The low output impedance of the emitter followers ensures that, when the potentiometer is in either the extreme clockwise or anticlockwise position, crosstalk travelling along the potentiometer tracks cannot appear at the outputs. Good channel separation in the stereo and reverse stereo modes is thus maintained.

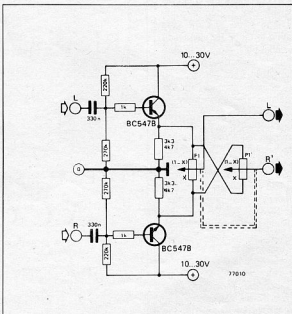

INFORMATION THEORY AND ENCRYPTION

by B.P. McArdle

Anyone who is, or becomes, involved in encryption operations and cryptosystems must wonder about their connection with Information Theory. In this article, Brian McArdle briefly explains the areas of overlap and difference.

Consider a channel where a message x_i drawn from a set $\{x_1, x_2, x_3, \dots, x_n\}$ of n possible messages, as illustrated in figure 1, is transmitted between sender A and receiver B. The message could be just a letter from an alphabet of n letters or a symbol. However, it is information of some type and is exchanged between A and B. The electronic representation of x_i could be a particular waveform or a set of binary digits (bits) etc. For example, the English alphabet of 26 letters requires a set of 5 bits to represent a letter and since $2^5=32$ there are 6 redundant combinations. For the present the method of signalling is not being considered. If each x_i has probability $\Pr(x_i)=p_i$ of being chosen for transmission by A the information **entropy** of the channel is given by the equation

$$H = - \sum_{i=1}^n p_i \log_2(p_i) \quad (1)$$

The minus sign makes H positive because every $p_i \leq 1$. The base of the logarithm does not have to be 2 but this means that the dimension of H is bits. If a particular message x_i has $p_i=1$ which means that $p_j=0$ for $j \neq i$, then $H=0$. If all messages are equally likely to be transmitted (uniform distribution)

$$H = \log_2(n) \quad (2)$$

which is the **maximum** value and is also the number of bits required to represent a message. The larger the value of H the greater the **uncertainty** in the information transmitted over the channel. If $H=0$ there is no uncertainty and the re-

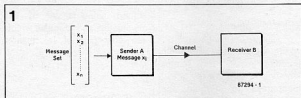

ceiver B does not receive false information. If the channel is very noisy such that the signals are corrupted during transmission this adds to the problems of the receiver. However the techniques used to reduce the effects of noise are not being examined in this article. And the technical limitations of the channel, such as in the Hartley-Shannon Law are not considered.

A priori and a posteriori information

The receiver may have some advance information before the message is sent. This is known as a priori information and the a priori probability is the probability that it is correct. The a posteriori information and the associated a posteriori probability refer to the transmitted message after it is received. These are commonly used parameters in Information

Theory but are not used in this article.

Encryption operation

If x_i is encrypted as illustrated in figure 2

$$E_K(x_i) = y_i \quad (3)$$

the electronic representation of y_i instead of x_i is transmitted. It is easier to keep track of the explanation by taking the x_i 's and y_i 's to be letters but this is not essential. The encryption operation is varied by changing the parameter K called the key. This is the secret information and should be known only to sender and receiver. The plaintext (or cleartext) and ciphertext are x_i and y_i respectively. An unauthorized listener (cryptanalyst) on the channel would probably know the method of encryption but not the actual key in use. The strength of the encryption oper-

ation is determined by the difficulty in deducing the key from the ciphertext. Modern cryptosystems also require that the key should not be deduced from a matched plaintext-ciphertext pair(s). However, this point is not developed further because we are not actually analysing particular systems. The relationship between Encryption and Information Theory is now considered by outlining the results of a famous paper.

Shannon's theory

Shannon (Ref.1) in his paper compared the effects of secrecy operations to the problem of noise. The letters of the ciphertext should appear random with no preference for any particular letter(s) but only the correct key will produce a meaningful message after decryption. He assumes that a cryptanalyst knows or can deduce the method of encryption (which we will not examine here) and has unlimited ciphertext but no plaintext-ciphertext pairs. He explains the requirements of a cryptosystem using the following parameters:

- (a) entropy of the plaintext $H(X)$ computed as per equation (1);
- (b) entropy of the ciphertext $H(Y)$ computed as per equation (1);
- (c) key entropy $H(K)$ computed as per equation (1);
- (d) key equivocation computed according to the equation

$$H(K/Y) = - \sum \Pr(K_i/Y) \log_2 \Pr(K_i/Y) \quad (4)$$

with joint and conditional probabilities

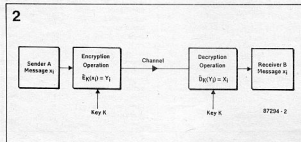

abilities being used. We need not be concerned with the various steps in the analysis but he deduces the following result

$$H(K/Y) = H(K) - H(Y) + H(X) = H(K) - nD \quad (5)$$

where D is defined as the **Redundancy**. The dimension is bits per symbol which is usually a letter. This parameter requires further explanation because it is central to the theory and conclusions.

Most languages have a peculiarity that certain letters occur more often than other letters. Consider a message which is encrypted by replacing each letter with another letter according to some rule. A good cryptosystem will result in a ciphertext which has a uniform distribution of letters such that no letter or group of letters occurs too often. This means that $H(Y)$ and $H(X)$ have different values. Although they are both measures of uncertainty, the difference between them is a measure of redundancy. Obviously, $H(Y)$ will be larger than $H(X)$ from equation (2). For English $D=3.2$. If $H(Y)=H(X)$, then $D=0$ and $H(K/Y)=H(K)$ and even unlimited amounts of ciphertext encrypted with the same key do not reveal the key. Thus one of the most important conclusions of the paper is that cryptanalysis is only possible because of language redundancy.

The 2nd important parameter is the **Unicity Distance** given by

$$U = H(K)/D \quad (6)$$

whose dimension is symbols or letters. This is the number of letters of the ciphertext required to determine uniquely the key (remember that Shannon assumes that a cryptanalyst knows the method of encryption and has unlimited ciphertext but no plaintext).

Example 1

Consider a simple substitution as follows:

Plaintext: A B C D E F G H I J K
L M N O P Q R S T U V W X Y Z
Ciphertext: G Z W J P A B I M T
D N E C S O Y X V H L F K Q R U

The number of possible tables which is the equivalent of the various keys is $26!$ such that

$$H(K) = \text{LOG}_2(26!) \quad (7)$$

$$\therefore U = 28(\text{approx.}) \quad (8)$$

which agrees very well with practical results. Any reader who wishes to know the actual techniques to deduce the tables should refer to (Ref.2).

Example 2

Consider the Data Encryption Standard (Ref.3) which turns a 64 bit plaintext block into a 64 bit ciphertext block using a 56 bit key block (Fig. 3).

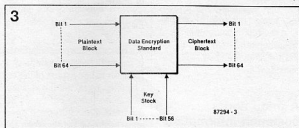

$$H(K) = \text{LOG}_2(26!) = 56 \quad (9)$$

$$\therefore U = 18(\text{approx.}) \quad (10)$$

From Shannon's Theory, this means that 18 blocks are required to establish that a decrypted message is meaningful text. If 8 bit ASCII is used, then 18 blocks = 144 symbols. However, since the ASCII alphabet has 128 symbols, the result is not too different from example 1. In reality, a cryptanalyst could not try each key of 286 possible keys but the example does illustrate the principle quite satisfactorily. The other parts of Shannon's paper need not be considered in presenting a short overview. However, his results are deduced using many of the parameters and formulae which are now part of Information Theory.

Conclusions

Encryption is not really a branch of Information Theory. There are important areas of overlap but the theories and techniques for the evaluation of modern cryptosystems, such as the Data Encryption Standard or

RSA Public Key Cryptosystem (Ref.4) have become subjects in their own right. Any student who wishes to study Cryptology would be well advised to start with basic Information Theory and Shannon's paper.

Appendix

Equation (4) can also be written in the form

$$H(K/Y) = - \sum_{j=1}^m \sum_{i=1}^n \Pr(k_i, y_j) \cdot \log_2 \Pr(k_i/y_j) \quad (11)$$

where m is the number of possible keys. The other form is commonly used in text books.

References

- (1) Shannon, Claude E.; *Communications Theory of Secrecy Systems*. Bell System Technical Journal, volume 28 (1945).
- (2) Friedman, William F.; *Elements of Cryptanalysis*. Aegean Park Press: U.S.A. (1976).
- (3) *Data Encryption Standard*. FIPS PUB 46 National Bureau of Standards, Washington DC, U.S.A. (1977).
- (4) Rivest, R.L. and Shamir, A. and Adleman, J.; *A Method for obtaining Digital Signatures and Public Key Cryptosystems*. Communications of the ACM, volume 26, number 1 (1983).

ELECTRONIC AND MAGNETIC QUANTITIES.

Quantity	Symbol	SI Unit	Abbr.	Quantity	Symbol	SI Unit	Abbr.
electric current	I	ampere	A	reluctance	R, R_m	reciprocal henry	1/H
electric charge, quantity of electricity	Q	coulomb	C	permeance	A	henry	H
electric field strength	E	volt per metre	V/m	phase displacement	ϕ	—	—
potential difference	U	volt	V	number of turns on winding	N	—	—
electromotive force	E	volt	V	impedance	Z	ohm	Ω
electric flux	ψ	coulomb	C	reactance	X	ohm	Ω
capacitance	C	farad	F	quality factor	Q	—	—
magnetic field strength	H	ampere per metre	A/m	admittance	Y	siemens	S
magnetic potential difference	U_m	ampere	A	susceptance	B	siemens	S
magneto motive force	F, F_m	ampere	A	active power	P	watt	W
magnetic flux density	B	tesla	T	apparent power	$S, (P_a)$	watt	W
magnetic flux	Φ	weber	Wb	reactive power	$Q, (P_q)$	watt	(- V A)
self inductance	L	henry	H	metre	l	metre	m
mutual inductance	M, L_{12}	henry	H	frequency	ν, f	hertz	Hz
coupling coefficient	k	—	—	angular frequency	ω	hertz	Hz
velocity of light in a vacuum	c	metre per second	m/s	period	T	second	s
resistance	R	ohm	Ω	time constant	τ	second	s
resistivity	ρ	ohm metre	Ωm	thermodynamic temperature	T	kelvin	K
conductance	G	siemens	S	energy	E	joule	J
conductivity	$k, \gamma, (\sigma)$	siemens per metre	S/m				

CUMULATIVE INDEX 1987

Computers & microprocessors

16 Kbyte CMOS RAM for C64	10.53
16-Key input for MSX micros	9.47
32 Kbyte pseudo ROM	9.50
4-bit D-A converter	11.36
4-way DAC extension	9.92
A-D converter for joysticks	9.60
BASIC computer	12.26
Bidirectional parallel for C64	9.124
Bidirectional serial-parallel converter	9.41
Bus direction add-on for MSX extensions	9.79
Communication program for C64	9.58
Computerscope (2)	2.51
Digital to analogue converter for I/O bus	1.21
Discrete DAC	9.87
Drive selector	9.57
Junior Synthesizer	4.52
LED Logic flasher	12.45
Level adaptor for analogue joysticks	9.48
Light detector	9.38
Logic families	9.96
MSX extensions — 5: EPROM programmer (1)	4.31
MSX extensions — 5: EPROM programmer (2)	5.40
MSX extensions-4: I/O and timer cartridge	3.40
ROM/RAM card for Electron Plus One	3.32
Ram Extension for Quantum leap	9.108
Serial data converter	9.68
Simple D-A converter	9.43
Synchronization separator	9.67
Text display on junior computer	5.47
The Jr Computer as a frequency counter	3.45
Universal EPROM emulator	10.41
Universal control for stepper motors	2.31

Domestic

7-digit code lock	9.64
Automatic car aerial	12.40
Battery saver	3.39
Central heating control	9.96
Current monitor and alarm	9.53
Drill speed control	11.44
Electronic sand glass	9.128
Electronic weathercock	7.23
Flashing aid	9.123
Forced cooling for refrigerator	9.131
Fruit machine	9.110
Headlight alarm	10.52
In car ioniser	3.47
LCD panel meter	4.54
Light sensitive trigger	9.79
Mains failure alarm	9.34
Starting-pistol simulator	9.105
Synchronized slide changer	9.109
Telephone light	9.114
Thermometer	9.65
Toilet pointer	9.49

Audio & music

AF waveform generator	7.27
Active phase-linear cross-over network	10.48
Audio line drive	9.113
Biphase	4.38
Buzzer driver	9.52
Compressor	9.86
Current corrected AF amplifier	9.39
Digital audio selector	9.89
Digital volume control	9.61
Electronic potentiometers	5.22

Feedback in loudspeakers	5.19
Headphone amplifier	9.45
Integrated stereo amplifier	9.42
Intercom for motorcyclists	7.39
Limiter for guitars	9.72
Linkwitz filters	5.30
Loudspeaker protection	9.44
Low noise RIAA preamplifier	9.102
Low-noise microphone preamplifier	11.34
MW receiver	1.53
Patch catcher	9.77
SMD headphone amplifier	9.71
Simple preamplifier	9.83
Single-chip 40 W amplifier	9.88
Stereo indicator	9.66
Stereo preamplifier with tone control	9.98

Generators, oscillators and test equipment

8-channel voltage display	9.80
Analogue wattmeter	1.39
Autorangeing digital multimeter	7.42
Capacitance meter	6.29
Digital sine-wave generator	3.21
Divider cascade	9.130
Duty factor analyser	9.36
Electronic balance	1.26
Function generator	9.84
HC-based oscillators	9.66
HCU/HCT-based oscillator	9.89
Instrumentation amplifier	9.112
Logarithmic sweep generator	9.106
Low current ammeter	9.121
Pierce oscillator	9.65
Precision crystal oscillator	9.75
Precision rectifier	9.84
Preset extension for function generator	5.28
Sample & hold for analogue signals	9.127
Simple sweep generator	9.100
Spot sine-wave generator — 1	6.25
Spot sine-wave generator — 2	7.33
Temperature probe for DMM	1.51
True RMS meter	1.30
Two tone RF test oscillator	9.114
VLF add-on unit for oscilloscopes	3.27
Variable Wien bridge oscillator	9.93
Wien bridge oscillator	9.74

Informative articles

A tidal generator for energy and jobs	10.34
Background to hollow-emitter technology	11.54
Bursting the bubble myth	6.21
Computer science's Holy Grail	12.48
Digital signal processing	2.40
Electron microscopy comes to life	11.26
Flexi cell to beat battery weight	2.66
How does the human computer work?	6.32
Its master's voice	3.19
Lasers: an overview	8.29
Local area networking	5.44
Measurement of ventricular distances	10.31
Mobile satcoms for the future	8.21
New rival to the world's fastest Computers	1.42
Noise at high frequencies	1.57
RIMS: counting atoms	5.33
Remote control in astronomy	4.28
Research collaboration to boost IT	11.52
Robot arms with the versatility of humans	6.51
Satellite TV reception: your questions answered	4.46
Schools' equipment for tomorrow's scientists	5.45

Secondary breakdown in power transistors	5.25	Fast starting wiper delay	9.122
Single-chip microcontrollers	10.22	Flashing lights	9.83
Software for the BBC computer — 2:		Flashing rear light	9.59
the BBC Buggy	2.42	Halogen lamp dimmer	9.85
Software for the BBC computer — 3:		Hybrid cascode	8.45
PCB design	3.35	Infrared light gate	8.46
Software for the BBC computer — 4:		Metal detector	6.35
analogue circuit design	4.43	Noise blanker	9.117
Solar power generation	8.24	Non interlaced picture	
Speech recognition system from Marconi	6.39	for electron	9.115
Stream encryption	10.28	PWM Driver for DC motors	9.126
Stretchable convex mirrors	6.53	Power Switch for cars	9.107
Switch-mode power supplies	11.45	Section indication for model railway	9.48
Testing the instruments of tomorrow	10.26	Selective calling in CB radios	7.24
The Inmos transputer and Occam	12.41	Speed control for DC motors	9.62
The birth of satellite communications	12.22	Speed control for R/C models	9.90
The compact disc	8.34	Timer for fixing bath	9.38
The desk-top supercomputer	11.53	Timer for soldering iron	9.99
The digital audio tape recorder	12.34	Tracking window comparator	9.81
The future belongs to the photon	2.28	Wiper delay	9.119
The magnetic way to painless brain			
stimulation	7.22		
The razor edge of the excimer laser	3.25		
The ultimate solid-state memory?	4.24		
Where electronic messages have the edge	5.37		
Where students make their own chips	8.42		
The UNIX operating system	12.38		
Communication security	1.24		

Design principles and ideas

ATN Filmnet decoder	8.44
An introduction to DC power supplies	6.47
Band-gap voltage reference	9.52
Decoding satellite TV signals	6.42
Decoupling in logic circuits	9.78
Deglitcher	9.116
Driver IC Type TDA7260 for class D	
amplifiers	7.45
Eight-channel multiplexer	7.26
Electronic potentiometers	5.22
Field-effect optocoupler	3.37
Filters-theory and practice — 1	8.38
Filters-theory and practice - 2	10.36
Filters-theory and practice - 3	11.30
HC-based oscillators	9.66
HCU-HCT-based oscillator	9.89
High-current switching regulator IC	
for SMPSUs	11.24
Linkwitz filters	5.30
Low voltage drop regulators	9.82
Low-noise amplifier Type TDA 7232	6.23
Micro-squeaker	3.36
Morse call sign generator	4.65
Negative Supply from	
Positive supply	6.28
OpAmp-based current source	9.56
Pierce oscillator	9.65
Precise motor speed regulator chip	12.46
Printed resistors	7.31
Simple 555 tester	6.41
The positive impedance converter	11.50
Transistor solar cell	6.46
Transmission lines for TTL circuits	9.69
Voltage drop detector	6.52

Miscellaneous

6-way channel selector	9.49
Auto focus for slide projector	9.56
Buzzer driver	9.52
Car stabiliser	8.37
Computer controlled enlarger	9.132
Dimmer for inductive loads	12.43
Display intensity control	9.39
Driver for bipolar	
stepper motors	9.120
Ergonomic Thumbwheel	
Switch	9.125

Power supplies & ancillaries

Battery charge/discharge	
indicator	9.113
Band-gap voltage reference	9.52
Current indicator for 723	9.63
Current monitor and alarm	9.53
Digital voltage/current display	9.35
Dimmer for inductive loads	12.43
High-current switching regulator IC for	
SMPSUs	11.24
Loss-free supply protector	9.96
Low voltage drop regulators	9.82
Precision power supply	2.44
Tunnel diode battery charger	9.70

RF, infra-red & video

ATN Filmnet decoder	8.44
Decoding satellite TV signals	6.42
Four-way aerial switch	9.76
Front-end for FM receiver	9.97
Front-end for SW receiver	9.132
High level passive DBM	9.51
High level wideband RF preamplifier	9.34
Indoor unit for satellite TV reception	2.21
MW receiver	1.53
Morse filters	9.73
RF module for IDU	9.40
SCART adaptor for IBM PC	4.41
SSB adapter	11.42
Switchable bandselector	9.94
Synchronization separator	9.67
Synthesizer for SW receiver	9.91
Top of the range preamplifier-2	1.44
Video distribution amplifier	9.118
Weather satellite interface	9.111

Corrections

16 Kbyte CMOS RAM for C64	11.80
Active phase-linear cross-over network	12.72
Analogue wattmeter	3.74
Computerscope	3.74, 5.72, 7.72, 10.80
D — A converter for I/O bus	8.72
Digital sine-wave generator	12.72
Headphone amplifier	10.80
High power AF amplifier	7.72
In Car Ionizer	4.80
Low noise aerial booster	1.82
Precision power supply	5.72
Preset extension for function generator	11.80
Printed resistors	10.80
Stream encryption	12.72
Synchronized slide changer	10.80
Synthesizer for SW receiver	10.80
Toilet pointer	10.80
Top-of-the-range preamplifier	1.82
True RMS meter	5.72
Universal control for stepper motors	3.74, 8.72

READERSHIP SURVEY

Since our last readership survey Elektor India has undergone a number of changes, brought about in the main as a result of your responses to the questions asked then, and also to keep abreast of our fast changing electronics environment.

To make sure we remain on the right track, we ask all of you to take a few minutes to answer the 20 questions here by ticking the relevant box and post the completed form to:

Elektor Electronics Pvt. Ltd.

52-C, Proctor Road,
BOMBAY-400 007

Your likes and dislikes

1. What areas of electronics are of most interest to you?

- Audio & hi-fi (1)
 Electrophonics (2)
 TV & video (3)
 HF/VHF/UHF (4)
 Computers (5)
 Computing science (6)
 Telecommunications (7)
 Test & measurements (8)
 Domestic applications (9)
 Hobby applications (10)

How interesting do you find the following features?

	wouldn't read Elektor India without it (1)	would like more (2)	I'm neutral (3)	would rather see less (4)	waste of paper (5)
2 Editorial	<input type="checkbox"/>	<input type="checkbox"/>	<input type="checkbox"/>	<input type="checkbox"/>	<input type="checkbox"/>
3 News	<input type="checkbox"/>	<input type="checkbox"/>	<input type="checkbox"/>	<input type="checkbox"/>	<input type="checkbox"/>
4 Book reviews	<input type="checkbox"/>	<input type="checkbox"/>	<input type="checkbox"/>	<input type="checkbox"/>	<input type="checkbox"/>
5 New products	<input type="checkbox"/>	<input type="checkbox"/>	<input type="checkbox"/>	<input type="checkbox"/>	<input type="checkbox"/>
6 Letters	<input type="checkbox"/>	<input type="checkbox"/>	<input type="checkbox"/>	<input type="checkbox"/>	<input type="checkbox"/>
7 Reviews of commercial equipment	<input type="checkbox"/>	<input type="checkbox"/>	<input type="checkbox"/>	<input type="checkbox"/>	<input type="checkbox"/>
8 Constructional projects	<input type="checkbox"/>	<input type="checkbox"/>	<input type="checkbox"/>	<input type="checkbox"/>	<input type="checkbox"/>
9 Informative articles on					
(a)electronics	<input type="checkbox"/>	<input type="checkbox"/>	<input type="checkbox"/>	<input type="checkbox"/>	<input type="checkbox"/>
(b)telecommunications	<input type="checkbox"/>	<input type="checkbox"/>	<input type="checkbox"/>	<input type="checkbox"/>	<input type="checkbox"/>
(c)computing science	<input type="checkbox"/>	<input type="checkbox"/>	<input type="checkbox"/>	<input type="checkbox"/>	<input type="checkbox"/>
(d)physics	<input type="checkbox"/>	<input type="checkbox"/>	<input type="checkbox"/>	<input type="checkbox"/>	<input type="checkbox"/>
(e)general science	<input type="checkbox"/>	<input type="checkbox"/>	<input type="checkbox"/>	<input type="checkbox"/>	<input type="checkbox"/>
(f) Selex	<input type="checkbox"/>	<input type="checkbox"/>	<input type="checkbox"/>	<input type="checkbox"/>	<input type="checkbox"/>

Buying habits

- ### 10 What do you look for in advertisements?
- Components (1)
 Measuring equipment (2)
 Computer hardware and software (3)
 Other commercial equipment (audio, video, domestic, etc.) (4)
 Books (5)
 Tools (6)

Reading habits

11 On average, how thoroughly do you read Elektor India?

- all articles (1)
 most articles (2)
 a few articles (3)
 I only leaf through (4)

Could you estimate how many hours, on average, you spend on this? hours

12 On average, how thoroughly do you look at the advertisements?

- I check them all (1)
 I look through most of them (2)
 I study a few (3)
 I only leaf through (4)
 I never look at them (5)

Could you estimate how much time, on average, you spend on this? hours

13 How do you usually obtain Elektor India?

- on subscription (1)
 from a newsagent (2)
 from a specialist electronics shop (3)
 borrowed from a friend, library (4)

14 If you are a subscriber, since when?

- recently (1)
 about a year (2)
 about two years (3)
 about three years (4)
 since it started in India (5)

15 If you buy your copy, how many other people read it?

- just myself (1)
 one other (2)
 three others (3)
 four others (4)

16 How many other specialist periodicals do you read regularly

17 Why do you buy *Elektor India*?

- Appealing cover (1)
- Professional appearance (2)
- Interesting articles (3)
- For the advertisements (4)
- For the INFO cards (5)
- For want of something better (6)
- Because I've read it for years (7)
- For my hobby (8)
- For my study (9)
- For my occupation (10)

Readership profile

18 Is electronics your

- profession? (1)
- study? (2)
- hobby? (3)

19 Education in electronics:

- No formal qualifications (1)
- Qualified technician (2)
- Professionally qualified (3)
- Corporate engineer (4)

20 Give the name of your.....

Village

Town

City

State

Please use this space for any further comments.

MULTI-FUNCTION FREQUENCY METER

An advanced, versatile and user-configurable test instrument capable of accurate measurement of frequency, frequency ratio and time interval. In addition to all this, it can be used as a period and event counter.

The multi-function test instrument described here is based on the 8-digit counter/timer IC Type ICM7226B from Intersil (GE/RCA). This chip combines all the functions expected from a good and versatile counter, and requires very few external components. The chip handles frequency measurement from DC to 10 MHz, period measurement from 0.5 μ s to 10 s, unit counting up to 10 million events, frequency ratio measurement, and time interval measurement. The inputs of the proposed instrument can accept a wide range of alternating (analogue) voltages as well as digital pulses at TTL or CMOS levels.

Circuit description

The circuit diagram of the frequency meter is given in Fig. 1. It would be beyond the scope of this article to give a detailed description of the internal operation of the ICM7226B, and the following is, therefore, an outline of the simple peripheral circuitry needed to obtain a complete instrument. A prescaler for extending the input frequency range to 1.2 GHz will be discussed in a forthcoming issue of *Elektor India*.

The ICM7226B has internal timebase circuitry, display decoders, segment and digit drivers. The 8-digit read-out is composed of common cathode LED displays multiplexed at 500 Hz and a duty factor of 0.122 per digit. Leading (non-significant) zeroes are blanked when the meter is set to frequency measurement in kHz or period measurement in μ s. LED D₉ indicates an overflow condition, i.e., the counter is "full", and all digits read 9.



The counter, IC₃, has an on-chip timebase oscillator which operates at 10 MHz (X₁). It is possible to use a 1 MHz quartz crystal provided S₅ is closed. Similarly, S₇ makes it possible to apply an external clock signal of 100 kHz or more to pin 33. When switch S₆ is closed, the position of the decimal point on the display is controlled externally via the respective input, pin 20. The decimal point can thus be positioned as required for the prescaler used. Switches S₈-S₉ and the associated diodes, D₆-D₇-D₈, are intended for the

above options on the frequency meter, and may be omitted when the relevant function is not required. It is, of course, also possible to replace the switches with wire links for permanent operation in a particular mode.

The maximum input frequency applied to input A of the instrument is 10 MHz in the frequency and unit count modes, and 2 MHz in the other modes. The counter modes and functions that can be selected with the RANGE switch, S_{4a-b}, and the FUNCTION switch, S_{2a-b}, are summarized in Table 1. Position 6 of

S₂ is used for checking whether the internal oscillator works, but not for verifying the frequency of oscillation. It should be noted that input B is only used for measuring frequency ratios and time intervals. The frequency of the signal applied to input A should be higher than that applied to B. Similarly, the pulse transition on input A should occur before that on input B.

The protective networks fitted at the inputs of N₅ and N₆ enable applying alternating voltages as well as CMOS or TTL (digital) pulses. For small alternating voltages applied via C₁-C₂, diodes D₁-D₂ or D₃-D₄ do not have a limiting effect, so that inverters N₅-N₆ operate as amplifiers. When the input amplitude is greater than about 2 V_{pp}, the inverters operate as buffers. Limiting of the input signal takes place when the input signal at the digital inputs is lower than -0.6 V or higher than +5.6 V. This means that AC coupled input voltages are clipped to about 6 V_{pp}. The input sensitivity stated in the circuit diagram is an average and frequency dependent value. When the Type 74HCT04 in position IC₂ (N₅...N₁₀ incl.) is replaced with a 74HCU04, the input sensitivity increases by a factor 5 to 10.

The circuit around N₇...N₁₀ incl. and XOR gates N₃-N₄ is used for measuring time intervals, i.e., the period that lapses between the positive edges of the signals applied to inputs A and B. A bistable internal to the ICM7226B is set and reset by the pulse transitions at input A and B respectively. When the bistable is set, the oscillator pulses are internally fed to the counter input. Evidently, the longer the bistable remains set,

Table 1

Switch S ₂ : FUNCTION	
Position	Function
1 (K1)	frequency (fA)
2 (K8)	period (T _A)
3 (K2)	frequency ratio (fA/fB; fA > fB)
4 (K5)	time interval (t _A →t _B)
5 (K4)	unit counter
6 (K3)	oscillator test
Switch S ₄ : RANGE	
Position	Accumulation time / cycle(s)
1 (K1)	0.01 s / 1 cycle
2 (K2)	0.1 s / 10 cycles
3 (K3)	1 s / 100 cycles
4 (K4)	10 s / 1,000 cycles

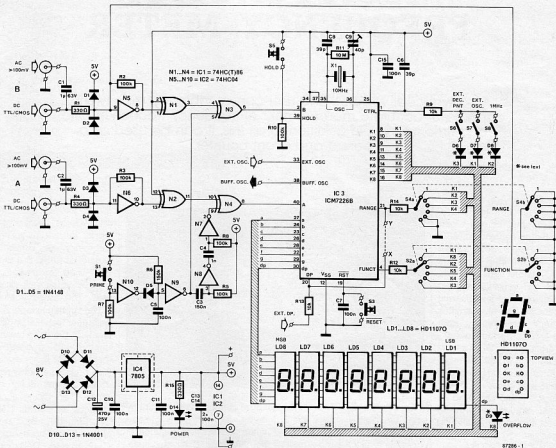

Fig. 1 Circuit diagram of the multi-function frequency meter.

the more pulses are counted, and the higher the read-out on the display. Push-button PRIME is pressed before measuring the time interval for a single event. Inverters N10-N5 generate a brief pulse for chip input A; N5-N7 a slightly delayed pulse for input B. The internal logic in the ICM7226B is thus primed ready for measuring the interval for one event, delimited by the positive edges of the pulses applied to instrument input A and B. Pressing PRIME is not required when these inputs are driven with a repetitive signal, as the first alternating signal states cause automatic priming of the counter chip.

The read-out can be retained ("frozen") as long as the HOLD switch, S5, is pressed. The counter's internal circuits—and hence the read-out—can be cleared at all times by pressing the RESET key, S3. Capacitor C7 is connected in parallel with S3 to prevent hang-ups at power

on. The 3 push-buttons can be fitted on the counter's front panel as suggested in Fig. 2. The power supply for the frequency meter is of conventional design, and requires no further detailing.

Construction

Virtually all parts shown in the

circuit diagram are fitted on a single printed circuit board, whose track layout and component mounting plan are shown in Fig. 3. Commence the construction with fitting all the wire links. Do not forget the 8 short ones underneath the displays! Electrolytic capacitor C12 is fitted at the track side of the board. Make sure that it is fitted

securely and slightly off the board to prevent sharp solder points piercing the insulating material and causing short-circuits with the grounded metal can. It is recommended to use good quality sockets for all integrated circuits. The displays are also fitted in 10-way sockets, made from terminal strips or 14-way IC sockets. Use

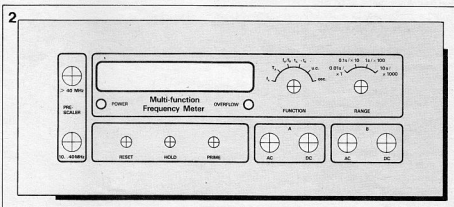

Fig. 2 Lay-out of the ready-made front panel foil for the frequency meter.

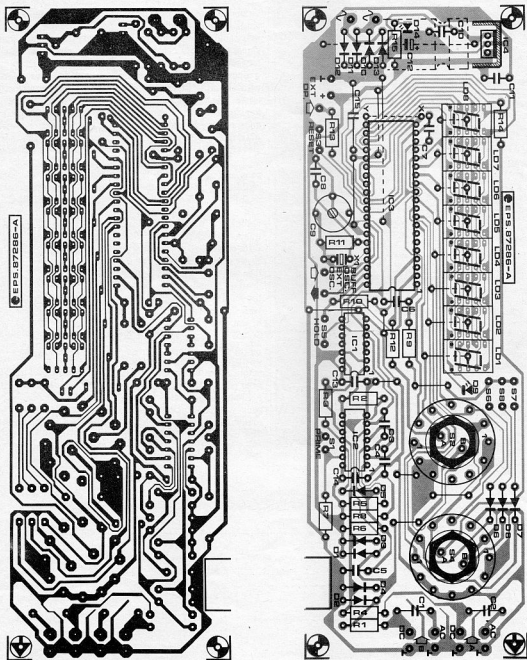
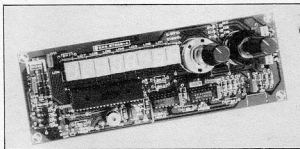

Fig. 3 Track layout and component overlay of the PCB for building the frequency meter. Capacitor C12 is fitted AT THE TRACK SIDE.

short lengths of strong wire to ensure the correct height of the displays above the board. LED D_9 is a high brilliance type whose leads are lengthened make its top is level with the displays in the sockets. Voltage regulator IC_4 should be mounted with a heat-sink. The RANGE and FUNCTION switches, S_1 and S_2 , are soldered direct onto the board, or with short lengths of left over component

wire, to minimize stray inductance and capacitance. This measure effectively prevents unwanted effects such as indeterminate illumination of digits ("ghosting"). As already stated, function switches S_1 - S_2 may not be required on the front panel of the instrument. Inputs A and B are made in flange-type or single hole BNC sockets. Two more of these are required when it is intended to



The completed printed circuit board (prototype version).

Parts list

Resistors ($\pm 5\%$):

R1;R4;R15=330R
R2;R3;R5;R7;R8;R10=100K
R6=150K
R9;R12;R13;R14=10K
R11=10M

Capacitors:

C1;C2=1 μ F; 63 V (non-electrolytic)
C3=150n
C4=1n0
C5;C7;C10;C11;C13;C14:
C15=100n
C6;C8=39p
C9=40p trimmer
C12=470 μ F; 25 V

Semiconductors:

D1...D5 incl.=1N4148
D6;D7;D8=1N4148 (see text)
D9=high brilliance LED (red)
D10...D13 incl.=1N4001
D14=red LED
IC1=74HC86 or 74HCT86
IC2=74HCU04 or 74HCT04
IC3=ICM7226BIJL or ICM7226BIPL*
IC4=7805
LD1...LD6 incl.=common cathode LED display HD11070*

Miscellaneous:

S1;S3;S6=push-to-make button.
S2=2-pole 6-way rotary switch for PCB mounting.
S4=2-pole 4 or 6-way rotary switch for PCB mounting.
S6;S7;S8=miniature SPST switch (see text).
X1=10 MHz quartz crystal.
TO220 style heat-sink for IC4.
Verobox enclosure Type 4775-1411.
PCB Type 87666 (available through the Readers Services).
Front panel foil Type 87286F (available through the Readers Services).
Mains transformer 8 V; 0.5 A.
Mains entrance socket, fuse (100 mA), and DPDT switch.
Knobs for rotary switches.
BNC sockets as required.

* Available from Universal Semiconductor Devices Limited
● 17 Granville Court
● Granville Road ● Horseley
● London N4 4EP. Telephone:
(01 384) 9420. Telex: 25157
usdco g. Fax: 01 348 9425.

* Switch with adjustable stop, e.g. Lorlin Type CK1045 (Circuit stock no. 53-21045).

extend the frequency meter with the prescaler to be introduced. Inputs ext. osc, ext. D_9 , and output buff. osc, can be made in suitable sockets on the rear panel of the enclosure. The signal at buff. osc can be used for setting the oscillator frequency to 10.000 MHz precisely with the aid of trimmer capacitor C5. It is also possible to use the signal for driving other circuits, provided the buff. osc output is fitted with a 10K resistor to the +5 V rail.

The supply voltage for the prescaler is available on 2 soldering pins next to the ext. D_9 input.

The completed PCB is mounted vertically in the moulded guides provided in the bottom plate of the Vero enclosure. The ready-made front panel foil for the frequency meter can be used as a template for drilling the metal front panel provided with the enclosure. The shafts of the rotary switches, S2 and S4, are cut to size to enable fitting suitable knobs. The LED displays are fitted in a rectangular clearance cut in the front panel. The visibility of the read-out is enhanced by the semi-transparent bezel in the ready-made front panel foil. The overflow indicator, D9, is fitted immediately below the

right-hand side of the display bezel. The position of the various controls and indicators is evident from Figs. 2 and 4. It is, of course, possible to use a ready-made mains adapter with 8 VAC output for powering the instrument. In many cases, this is safer and less expensive than incorporating a mains transformer. When it is still intended to furnish the frequency meter with its own, internal, mains supply, the mains socket and fuse (100 mA) should be fitted at safe locations onto the rear panel of the enclosure. The mains transformer should be preferably an 8 V, 0.5 A type. The current consumption of the circuit is about 55 mA with all displays blanked, and 175 mA with all displays illuminated. ■

Reference:

Component Data Catalog 1987: ICM7226A/B p. 14-80 ff. Intersil GE/RCA International Limited ● Beech House ● 373-399 London Road ● Camberley ● Surrey GU16 3HR. Telephone: (0276) 685911. Fax: (0276) 685255.

4

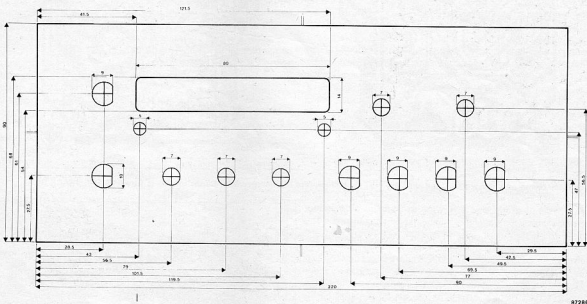

Fig. 4. Drilling diagram for the front panel.

NUMBERS AND THE MACHINE

by C.H. Freeman

Computer science depends largely on the properties of real numbers. The correct use of these requires an understanding of the mathematic basis of the real number system. Unfortunately, many people shy away from anything mathematical, even if it has only to do with numbers. This article attempts to allay these misgivings.

Modern man counts in base ten, that is, he uses the ten individual symbols 0, 1, 2, ..., 8, 9. Obvious, you might say, but it hasn't always been so. Some races have been known to count in base 20 (by using their toes and fingers in arithmetical operations) and the concept of zero itself is quite new; consequently, the Romans, who had no representation for zero, had endless trouble with arithmetic. In general, an n digit integer, No , can be represented by

$$No = d_n R^n + d_{n-1} R^{n-1} + \dots + d_1 R^1 + d_0 R^0$$

or

$$No = \sum_{i=0}^n d_i R^i$$

where d^1, d^2, \dots, d^n are the decimal symbols in the counting system and R is the number base we are working in. When we count in decimal, the symbols used are 0, 1, 2, ..., 9 and R , the base (or *radix*), is 10. Thus we can represent, say, 50465 as

$$5 \times 10^4 + 0 \times 10^3 + 4 \times 10^2 + 6 \times 10^1 + 5 \times 10^0$$

Now, although this suits us humans very nicely, digital systems do not use ten discrete values when representing numbers; the engineering problems introduced in using such a system would be too great. Instead we use base two, more commonly referred to as *binary*. The binary system has just two decimal digits in its counting system: 0 and 1. Now, this is handy because a switch, be it electronic, mechanical, hydraulic, pneumatic etc., can be either on or off and can thus be made to represent a single binary digit (or *bit*): the deriva-

tion arising from Binary digit(T). So, using the above expression, a string of binary digits, such as 11001, can represent the decimal number

$$1 \times 2^4 + 1 \times 2^3 + 0 \times 2^2 + 0 \times 2^1 + 1 \times 2^0 = 25$$

and we can now see how any positive decimal integer can be represented in binary, and also how to transform a binary number into its decimal equivalent. But what about translating decimal into binary? What do we do then? The answer is, we simply divide our decimal repeatedly by 2, recording the remainder at each stage of the division. The series of remainders, when read 'from the bottom up', form our binary number. Let's try an example, converting 229 into binary

229 ÷ 2	
114 remainder 1	
57 remainder 0	
28 remainder 1	
14 remainder 0	
7 remainder 0	
3 remainder 1	
1 remainder 1	
0 remainder 1	

thus 229 = 11100101. Check this for yourself by converting the number back into base 10.

What we have just discovered about converting decimal to and from base two applies equally well to base 3, base 7, base 9 or, in fact, any base you care to name. Actually, two other bases, base 8 and base 16 (known as *octal* and *hexadecimal* respectively), are important, but more of this later. For the moment, though, you may well be wondering about base 16 (or *hex* as it is usually known). After all, base 16 will

have 16 individual symbols in its counting system and after going through the symbols 0-9 we run out! Mathematicians, when faced with problems such as these, invariably do the decent thing — and cheat. In this case the letters A-F are pressed into service and the full counting system runs 0, 1, 2, 3, 4, 5, 6, 7, 8, 9, A, B, C, D, E, F.

Binary addition

Two binary numbers are added together in the same way two decimal numbers are added together: by adding together individual digits, paying due attention to any carry digits generated. As there are just 2 digits in the binary system, there are 4 possible sums which can be formed. These are

	sum	carry
0 + 0 =	0	0
0 + 1 =	1	0
1 + 0 =	1	0
1 + 1 =	0	1

Using this principle, we can generate a table of binary numbers alongside their decimal equivalents. Part of such a table for a 4 bit binary is shown in Table 1.

TABLE 1.

2 ³	2 ²	2 ¹	2 ⁰	DECIMAL	HEX
0	0	0	0	0	0
0	0	0	1	1	1
0	0	1	0	2	2
0	0	1	1	3	3
0	1	0	0	4	4
0	1	0	1	5	5
.
.
.
.
1	1	1	0	14	E
1	1	1	1	15	F

It is at this point that octal and hex become interesting. By collecting adjacent bits into groups of four, we can write just one hex digit in place of each group. To illustrate, consider

$$59 = 111011 = 0011\ 1011 = 3B \text{ (hex)}$$

and it can be seen that hex notation can act as a useful 'short-hand' when writing long binary sequences. Note how we pad the number out with leading zeroes in order to obtain two 4 bit groupings. A similar technique can be adopted using octal by gathering bits into groups of three thus

$$59 = 111011 = 111\ 011 = 73 \text{ (octal)}$$

Signed integer representation

So far we have considered binary representation of positive integers only. What happens if we want our computer to hold a negative integer? Our system has so far made no allowance for such eventualities so what can be done? Fortunately, three possibilities exist. They are

(a) sign-magnitude representation.

This is the simplest possible method and relies upon the fact that computers hold numbers in fixed length registers. These registers are usually 4, 8, 16 or 32 bits in length, but the important fact is that their length is constant. If we have an n bit register, we can use the most significant bit as an indicator (or FLAG) to represent a positive or negative number. It is usual for

this bit to set (i.e. 1) when representing a negative number and reset (i.e. 0) when representing a positive. The rest of the $n-1$ bits hold the absolute value of the number. The greatest absolute value which can be held in such a register is $2^{n-1}-1$ so it follows that if a number is held in an n bit register in this form

$$\text{range} = 0 \text{ to } \pm(2^{n-1}-1) \text{ inclusive}$$

(b) diminished radix complement.

For an n digit number N_r in base R , we can form what is known as its diminished radix complement by applying the formula

$$\text{DRC} = (R^n - N_r) - 1$$

The name of the complement depends upon the base in which operations are being performed and takes the name of the highest decimal digit in the system. Thus the DRC of a decimal number is known as its *nines complement*, whilst that of a binary is referred to as its *ones complement*. With the above equation as a springboard, it is not difficult to show that the ones complement of any binary can be formed simply by inverting each bit, that is changing 1 to 0 and 0 to 1. For example,

0001 represents 1

1110 represents -1

Thus in an n bit system the greatest positive number will be held by only $n-1$ of the bits. Therefore, the greatest positive number is $2^{n-1}-1$. The greatest negative will be represented by a 1 in the most significant bit followed by $n-1$ zeroes. Hence range = 0 to $\pm(2^{n-1}-1)$ inclusive

(c) radix complement representation.

The radix complement of an n digit number N_r in base R can be calculated using the equation

$$RC = R^n - N_r$$

and the radix complement of a binary number is referred to as its *twos complement*. It should be clear that adding a number

to its twos complement will result in all zeroes plus an overflow carry. If the system in use ignores any digits in excess of n then the above equation reduces to

$$RC = -N_r$$

in other words, the radix complement represents the negative of a number in the same number of bits.

Computer circuitry can easily form a twos complement by firstly inverting all the bits of the number (to obtain a ones complement) and then simply adding 1 to the least significant bit. For us mortals there exists an easier method of translating a binary into its twos complement. Starting with the least significant bit, we copy all the bits in the number up to and including the first occurrence of one. The remaining bits are then inverted. Table 2 shows comparative representations for a 4 bit register. Note that in the case of twos complement representation

$$\text{range} = -(2^{n-1}) \text{ to } (2^{n-1}-1) \text{ inclusive}$$

and the minimum negative number *cannot* be negated.

Why bother?

If all this seems as if it is merely some abstract mathematical stuff, then let me assure you that it is not. All this maths has a very practical consideration in the design of computer hardware. You see, it is easy to build circuitry which can perform inversion of a binary and addition of

two binaries, but it is far less simple to build circuitry which can perform subtraction directly. This means that the process of subtracting one binary number from another is invariably reduced to two distinct operations: forming the complement of the subtrahend, and then adding this complement to the minuend. This leaves us with the decision as to which complement to use: ones complement or twos complement? If we choose to use twos complement, we simply add and then discard any carry which may arise from the most significant digit. If we use the ones complement, however, any such carry must be added to the least significant digit. If this generates further carry digits, they must be also added until no further carries are generated. This *end-around-carry* means that arithmetic performed with the twos complement system is a much simpler business than all that mucking about in ones complement. Consequently, twos complement is the method computers will normally use when representing negative numbers. Let's look at an example, subtracting 13 from 42 to leave 29:

$$\begin{array}{r} 42 = 101010 \quad 13 = 001101 \\ \underline{ - } \\ 29 = 011101 \end{array}$$

Ones comp. of 13 = 110010,
+1 = twos comp. = 110011

$$101010 + 110011 = 1011101$$

Discarding carry leaves
011101 = 29

This looks more complicated

than it actually is. To a person, performing such a process seems quite alien, but computer circuitry finds the process beautifully simple. And speaking of simplicity, the world of numbers is not limited to the simple system of integers. We must now examine how we can represent the system of natural numbers in binary.

The real world

In our earlier look at binary numbers we saw how an n digit integer, N_{10} , in base R could be represented in the following manner:

$$N_{10} = d_n R^n + d_{n-1} R^{n-1} + \dots + d_1 R^1 + d_0 R^0$$

We now extend this to enable us to represent any finite length real number using the following representation:

$$N_{10} = d_n R^n + \dots + d_1 R^1 + d_0 R^0 + d_{-1} R^{-1} + d_{-2} R^{-2} + \dots$$

Now, when we use binary to represent such a number, we are using

$$N_{10} = d_n \times 2^n + \dots + d_1 \times 2^1 + d_0 \times 2^0 + d_{-1} \times 2^{-1} + d_{-2} \times 2^{-2} + \dots$$

and it should be easy to see that we can hold a binary fraction in a register, using the most significant bit to represent 2^{-1} , etc.

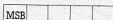

$$2^{-1} \quad 2^{-2} \quad 2^{-3} \quad 2^{-4} \quad \text{etc.}$$

TABLE 2.

REGISTER BIT PATTERN	POSITIVE INTEGERS	ONES COMPLEMENT	TWOS COMPLEMENT	SIGN MAGNITUDE	HEX	OCTAL
0111	7	+7	+7	+7	7	7
0110	6	+6	+6	+6	6	6
0101	5	+5	+5	+5	5	5
0100	4	+4	+4	+4	4	4
0011	3	+3	+3	+3	3	3
0010	2	+2	+2	+2	2	2
0001	1	+1	+1	+1	1	1
0000	0	+0	+0	+0	0	0
1111	15	-0	-1	-7	F	17
1110	14	-1	-2	-6	E	16
1101	13	-2	-3	-5	D	15
1100	12	-3	-4	-4	C	14
1011	11	-4	-5	-3	B	13
1010	10	-5	-6	-2	A	12
1001	9	-6	-7	-1	9	11
1000	8	-7	-8	-0	8	10

Table 3 shows a three-bit register holding binary fractions in just such a way, along with the decimal equivalent of its contents. This table also shows the method of converting a binary fraction into a decimal fraction. By inspection, it should also be easy to see that such an n bit register can hold values in the range

0.0 to $(1.0 - 2^{-n})$
in steps of 2^{-n} .

Before going any further, we'll take a look at how we convert decimal fractions into binary fractions. Decimal integers, as we saw earlier, are converted into their binary equivalents by repeated division by two, recording the remainder at each stage. Decimal fractions, on the other hand, are repeatedly multiplied by two. At each stage, the resulting integer part is separated from its fractional part and forms a bit in the resulting binary. The process is better illustrated by example than by words so let's convert 0.375 into binary:

$$\begin{aligned} &0.375 \times 2 \\ &0 + 0.750 \times 2 \\ &1 + 0.50 \times 2 \\ &1 + 0.0 \text{ process completed.} \\ &0.375 = 0.111 \end{aligned}$$

Try converting a few decimals into their binary equivalents, and then convert them back into decimal again. You'll soon get the hang of it! Now we know how to convert a decimal real into a binary real let's think about how we can store such a number inside a computer.

If we think of a binary number as having two separate constituents, an integer part and a fractional part, then it would seem an obvious move to store such numbers in the following way:

M BITS
INTEGER
PART

N BITS
FRACTIONAL
PART

leading us to suppose we can store numbers in steps of 2^{-N} . In fact, this is a very poor way to store numbers. When very large or very small values are represented in such a way, it is found that there can be vast amounts of 'wasted space'. This is inevitable whenever such a fixed point system is adopted and a much better bet is...

TABLE 3.

REGISTER BIT PATTERN	SUM	DECIMAL
0 0 0	0 + 0 + 0	0.000
0 0 1	0 + 0 + 2	0.125
0 1 0	0 + 2 + 0	0.250
0 1 1	0 + 2 + 2	0.375
1 0 0	2 + 0 + 0	0.500
1 0 1	2 + 0 + 2	0.625
1 1 0	2 + 2 + 0	0.750
1 1 1	2 + 2 + 2	0.875

Floating point representation

Floating point representation relies on the fact that any number in base R can be split into two parts, its *mantissa*, M , together with its corresponding *exponent*, E , and depicted as

$$M \times R^E$$

In decimal, of course, this corresponds to the familiar exponential notation (powers of ten) we all know and love. If we consider the binary number 101.1101 (for example) then it can be written in mantissa and exponent form as

$$101.1101 \times 2^0 \text{ or } 1011.1 \times 2^{-3} \text{ or } 0.1011101 \times 2^4$$

The last notation is, in fact, the usual method of writing binary reals, with the most significant set bit coming immediately after the decimal point. Such a number is said to be **NORMALIZED** in point of fact this is almost exactly how computers do store real numbers within their memories, as two distinct series of bits representing mantissa and exponent. You've probably also noticed by now that numbers stored in this way will have the most significant bit of the mantissa apparently redundant (as it appears it will always be zero). This is no accident. Negative as well as positive mantissas and exponents must be catered for and in such cases the mantissa is held in twos complement form, the most significant bit being taken as a sign bit. Remember that such a bit will usually be set if the number it represents is negative, and reset if the mantissa is positive. The exponent is also held in twos complement form (see below)

SIGN BIT	MANTISSA	SIGN BIT	EXPONENT
----------	----------	----------	----------

Let's try and illustrate this by considering a fictional computer holding numbers in two 4 bit registers:



$$\text{SIGN } 2^{-1} \quad 2^{-2} \quad 2^{-3}$$



$$\text{SIGN } 4 \quad 2 \quad 1$$

The mantissa, remember, is normalized so it can take the bit patterns (ignoring the sign bit and considering 2^{-1} as the most significant bit)

111, 110, 101, 100 corresponding to the decimals

$$0.875, 0.750, 0.625, 0.500$$

and for negative mantissas the possible range which can be stored is

$$-1.000, -0.875, -0.75, -0.625$$

and we get the range for our mantissa

$$-1.0, -0.875, -0.75, -0.625, 0, 0.5, 0.625, 0.75, 0.875$$

The exponent can take the range +7 to -8 in steps of 1, of course. The numbers we can represent in our 'machine', therefore, will be

$$0.875 \times 2^7 = 112$$

$$0.750 \times 2^7 = 96$$

$$0.625 \times 2^{-8} = 5/2048$$

$$0.500 \times 2^{-8} = 4/2048$$

0

$$-0.625 \times 2^{-8} = -5/2048$$

$$-0.750 \times 2^{-8} = -6/2048$$

$$-0.875 \times 2^7 = -112$$

$$-1.000 \times 2^7 = -128$$

Notice that because of the twos complement method of storing our mantissa there are two numbers which cannot be negated: the minimum positive real and the minimum negative real.

A 'proper' computer would, of course, use many more bits than 4 to represent numbers but the principle is exactly the same as that outlined for our 4 bit example above.

Range and accuracy

It is clear, judging by the example above, that there are some decimals which can never be represented exactly, for the reason that there simply aren't enough bits available to fit the number in. For example, $109 = 0.1101101 \times 2^7$

$$109 = 0.1101101 \times 2^7$$

But the binary equivalent is too big to fit into our 4 bit mantissa. In cases such as these there are two options open. We can simply 'chop off' (or TRUNCATE) the excess bits and store as

$$0.110 \times 2 = 96$$

or we can ROUND the number up (or down accordingly) to

$$0.111 \times 2 = 112$$

Whatever happens, it should be realized that there will invariably be a degree of error in computer arithmetic. Usually such errors present no big problems and can be allowed for.

As far as range is concerned, if a machine stores numbers as M bit mantissas and N bit exponents, the greatest possible positive mantissa will be equal to

$$0.111 \dots 111$$

and will be equal to $1 - 2^{-(M-1)}$

and the greatest possible exponent will be given by $2^{N-1} - 1$. So,

greatest positive number – $(1-2^{-(M-1)}) \times (2^{N-1} - 1)$

As far as the smallest positive real is concerned, the mantissa will equal 2^{-1} and the exponent will be $2^{-(N-1)}$

Smallest positive number = $2^{-1} \times 2^{-(2^{N-1})}$

Try and work out the largest and smallest negative reals which can be represented. So there you have it! Computer arithmetic is not just so much arcane theory, but is a fascinating branch of mathematics: a branch which is in constant daily use in fields as

diverse as spacecraft navigation to preparing and printing your gas bill. The modern world is so very heavily dependent upon computers that it is doubtful whether it could function without their assistance. Love them or loathe them, you've got to admit that we need them!

The author would like to acknowledge the help of Mr. G Parkes, dept. of computer science, University of Hull, for his assistance in the preparation of this article.

multiple voltage supply

Many circuits using, for example, both op-amps and logic circuits, require more than one supply voltage. The circuit described here is designed to supply four voltages of +12, +5, -7 and -12 volts, with a maximum current of 50, 300, 50 and again 50 mA respectively.

The positive supply voltages are produced in the normal fashion, using positive voltage regulator ICs; for the negative voltages it would be possible to use the special ICs which have been designed for this purpose, however these are both fairly expensive and often difficult to obtain. For this reason an alternative solution was sought. Although the 723 was designed for positive voltages, it can also be adapted for negative output voltages if, instead of being used as a series-regulator, it is connected as a shunt stabiliser (IC3 and IC4).

Shunt stabilisers suffer from the disadvantage that a constant power is taken from the mains transformer, irrespective of whether they are feeding a load. This

means that this type of circuit is not particularly efficient; however in this case, where the maximum current is only 50 mA, the power loss is negligible.

The negative output voltages can be adjusted by means of P1 and P2. After adjustment, the series-connected potentiometer and resistor can be replaced by two series-connected resistors. All the voltages supplied by the circuit are short-circuit proof; that is to say that shorting the outputs will not damage the supply. The positive outputs are provided with the usual current limiting. In the case of the shunt regulators for the negative voltages, the short-circuit current is determined by the dropper resistors R7 and R13. These should be rated at 2 W (or more) to prevent overheating.

Note that it will not always be necessary to use such a complicated transformer (8-0-8-16 V). If the 5 V supply does not have to deliver much current, a 0-8-16 V (i.e. an 8-0-8 V!) transformer can be used. D2 and C2 are omitted in this case.

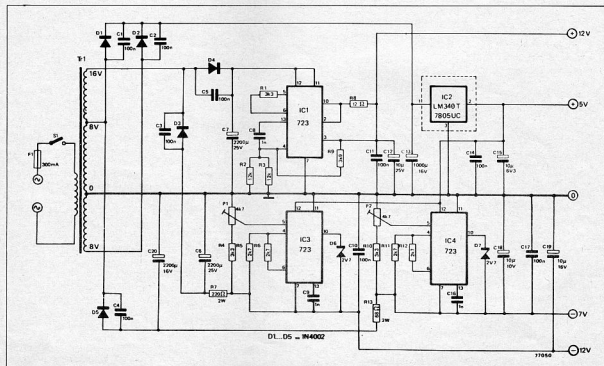

TOP-OF-THE-RANGE PREAMPLIFIER-3

This concluding part of the article deals with the construction of the preamplifier. Additionally, it gives a detailed discussion of the various types of capacitor, both myths and realities.

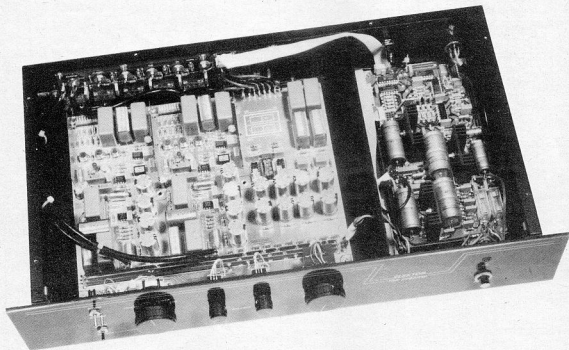

The preamplifier contains three printed-circuit boards: mother board, bus board, and supply board. The dimensions of the boards have been chosen to allow the unit fitting in a standard 19 inch cabinet with a height of 2 units (88 mm). The mains transformer is fitted in a separate aluminium enclosure, the dimensions of which are not critical. In addition to the PCBs, two foils are available through our READERS SERVICES: one for the front panel and one for the rear panel.

High-quality components

It is important to use only high-quality components to ensure optimum performance. All resistors should be metal film types with a tolerance of 1%, although that of R_7 and R_8 should preferably be 0.1%. If these prove unobtainable, select a pair of 1% resistors that are

identical in value, or very nearly so, with the aid of a digital multimeter.

All opamps are Type OP-27, while the dual transistors are MAT-02s. Do not use the OP-37 in the line amplifier, because this type has off-set compensation only for gains greater than 14 dB.

All capacitances in the signal paths are formed from a parallel combination of an MKT and an MKP capacitor (M=metals; K=plastic; T=polyterephthalate; P=polypropylene). Frequency-determining capacitors in the IEC compensation section (C_3 , C_6 , C_7) are 1% MKS (S=poly-styrene) types. Electrolytic capacitors in the power supply are all PCB mounting types. Decoupling capacitors shunting electrolytic capacitors may be MKT or ceramic types.

It is advisable to use silver- or gold-plated phono input sockets: these guarantee freedom from oxidation and conse-

quent contact potentials between plug and socket.

The relays on the bus print must, of course, be of prime quality. Four possible types are shown on the component list. The excellent SDS type is unfortunately polarized, and its coil connections are exactly the reverse of the others: if this type is used, therefore, its coil connections must be reversed.

The volume control potentiometer must be of the highest quality: in the prototype a stereo version from Alps was used with excellent results.

The balance potentiometers are rather less critical, but should still be of very good quality: they should definitely not be carbon types, but conductive plastic or cermet. Bourns or Spectrol models are recommended.

The switches are not critical components, since they only switch direct voltages to the relays.

A few tips to make the total cost come down somewhat. The OP-27 may be replaced by a 5534, which is a lot cheaper and still a good-quality device, but it may give off-set problems. The MAT-02 may be replaced by an LM394, but the overall quality will come down slightly. In this context, if moving-coil pick-ups are unlikely to be used, only one MAT-02 per channel is required as already explained in Part 2. Cost reductions on the capacitors should be well considered: whatever you do, never use electrolytic capacitors in the signal paths — at the very least MKT types should be used there.

Construction

The mains transformer, which can either be of the laminated or of the toroidal type, should be mounted in an aluminium case (see Fig. 13). From one end of this case the—non-earthed—

mains cable should emerge, and from the other a fairly heavy three-core cable terminated into a suitable plug. This plug mates with a corresponding three-pin socket at the rear of the preamplifier enclosure. This arrangement is absolutely essential to keep any hum from the preamplifier circuits.

Next, the supply board should be completed. The voltage regulators should be fitted onto adequate heat sinks, which can be fitted to the board with self-tapping screws.

When the board is completed, it can be mounted at the right-hand side of the enclosure. Do not forget a screen between it and the mother board. The alternating voltage from the mains transformer is taken to the board via the double-pole mains switch.

Mains on-off indicator D_{12} should now also be connected to the supply board.

The earth connection on the supply board is then connected to the enclosure via a short length of heavy-duty cable.

The supply may then be switched on to test whether the direct voltages are present: if so, they should be set to ± 18 V with the aid of the two presets $-P_1$ and P_2 .

The bus board can be complete fairly quickly. First screw up all the phono sockets to the board (inputs at the track side). Tighten them by hand and then solder them lightly to the board: this prevents them coming loose when later the corresponding plugs are withdrawn and plugged in again. Then tighten the socket nuts with a suitable spanner. After that all other components, including the relays, can be fitted onto the

board.

Some resistors are soldered direct to the centre terminal of the sockets.

The connections between socket and board at the tape and line outputs are made with a short length of equipment wire. The remaining connections are provided with soldering pins to make them easily accessible during the remainder of the work.

Remove any resin from the board with a brush dipped into white spirit or alcohol, and then seal the track side with a suitable plastic spray. Take care that no spray gets into the sockets or relays. This cleaning and insulating of the board reduces the risk of cross-talk to a minimum.

The board is then mounted to the rear panel of the enclosure with the aid of insulated spacers: this obviates any possibility of the tracks or sockets touching the enclosure.

The earth connection adjacent to the sockets must be connected securely to the enclosure to become the case earth: this same point should be connected to the central earth point on the supply board via a short length of cable.

The mother board should be completed in the following order: resistors; capacitors; mechanical parts; semiconductors. Make sure that non-insulated capacitors (if at all used) can not touch the screening at the top. Do not use sockets for the ICs.

At the front of the board, three supply rails have to be provided. To do this, first fit soldering pins in all the holes; then cut narrow strips of brass or tin sheet, and solder these to

Parts list (Fig. 15)

Components for one channel only are given; the corresponding ones for the other channel (dashed || in the drawings) are, of course, identical

Resistors (all metal film):

$R_1 = 20R$
 $R_2 = 4999F$
 $R_3 = 100R$
 $R_4, R_{16} = 1K0F$
 $R_5 = 49K9F$
 $R_6 = 150R$
 $R_7, R_8 = 1K5F$
 $R_9, R_{10}, R_{11} = 332R$
 $R_{12} = 348R$
 $R_{13} = 3K48F$
 $R_{14} = 3K16F$
 $R_{15} = 22K1F$
 $R_{16} = 1K21F$
 $R_{17} = 16R5F$
 $R_{18}, R_{19}, R_{20} = 2K2F$
 $R_{19} = 121K$
 $R_{20} = 475K$
 $R_{21}, R_{22} = 20K$
 $R_{23}, R_{24} = 15K$
 $R_{25} = 4K75F$
 $R_{26} = 3K92F$
 $R_{27}, R_{28}, R_{29} = 1M0F$
 $R_{27} = 475K$
 $R_{28} = 27K4F$
 $R_{29} = 182R$
 $R_{30}, R_{31}, R_{32}, R_{33}, R_{34}, R_{35}, R_{36}$
 $R_{37} = 10R$
 $R_{31}, R_{32} = 22R$
 $R_{35} = 6K8J$
 $R_{40}, R_{41}, R_{51} = 10K$
 $R_{52} = 100K$
 $P_1 = 10K$ J log potentiometer (e.g. Bourns Electronics*)
 $P_2 = 10K$ J log stereo pot meter (e.g. Alps RKGA-2 10K AX2**)

Capacitors:

$C_1 = 220\mu$ polystyrene
 $C_2, C_3 = 100\mu$ polystyrene
 $C_4 = 47\mu$ polystyrene
 $C_5, C_6, C_{12}, C_{14}, C_{16} = 10\mu$ MKT
 $C_7, C_{13}, C_{15} = 4\mu$ MKP
 $C_8 = 10n0$ polystyrene
 $C_9, C_{11} = 330n0$ polystyrene
 $C_{10} = 1n0$
 $C_{18} = 2\mu$ MKP
 $C_{19}, C_{17} = 470n$ MKT

$C_{18} = 100\mu$ M 3 V; tantalum electrolytic
 $C_{19}, C_{21}, C_{22}, C_{25}, C_{26}, C_{31}, C_{32}, C_{33}, C_{34}, C_{36}, C_{37} = 220n$ MKT
 $C_{35}, C_{39}, C_{38} = 100\mu$ M; 25 V
 $C_{23}, C_{24}, C_{27}, C_{28}, C_{44}, C_{45}, C_{46}, C_{48} = 1000\mu$ M; 25 V
 $C_{49} = 100n$ MKT
 $C_{50}, C_{51}, C_{52}, C_{53}, C_{54}, C_{55} = 22n0$ K ceramic

Semiconductors:

$D_1 = 1N4148$
 $D_8 = LED$ red
 $T_1, T_2, T_3 = MAT-02$
 $T_4 = 2N2291$
 $IC_1, IC_2, IC_3, IC_4 = OP-27^+$
 $IC_5 = LF411$

Miscellaneous:

$S_1 = 2$ -pole DIP switch
 $S_2 = 8$ -pole DIP switch
 $S_3 = SPST$ miniature
 $REG =$ sub-miniature PCB mounting relay; 2-pole change-over; 12 V (e.g. Meissei M1-12 or M1B12H); Siemens W11V23102-A0006-A1111* +; Omron G2V-2; SDS DS2E-M-12#
 16 silver- or gold-plated phono chassis sockets
 PCB 86111-3

*Distributors in UK:

Cambridge: Hi-Tek; telephone 10223/213333

Sevenoaks: Jermyn Distribution; telephone (0732) 450144

Harlow: STC Electronic Services; telephone (0279) 26777

*Armon Electronics; telephone 01-902 4321

+ Electrovalue; telephone (0784) 33903 or 061-432 4945

#May also be available from Electromail; telephone (0536) 204555

General note: many special audio components are available from Sage Audio, Bingley, West Yorkshire, telephone (0274) 568647 or 568647

Kord Audio Products, The Green, Nettleham, Lincoln, telephone: (0522) 750702

13

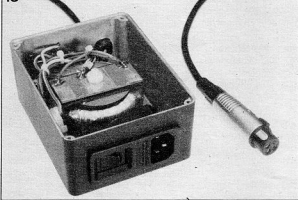

Fig. 13. The mains transformer must be housed in a separate metal case.

14

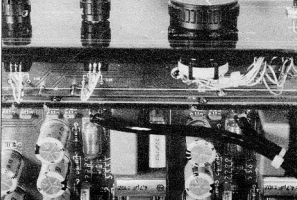

Fig. 14. Illustrating the three supply rails on the mother board.

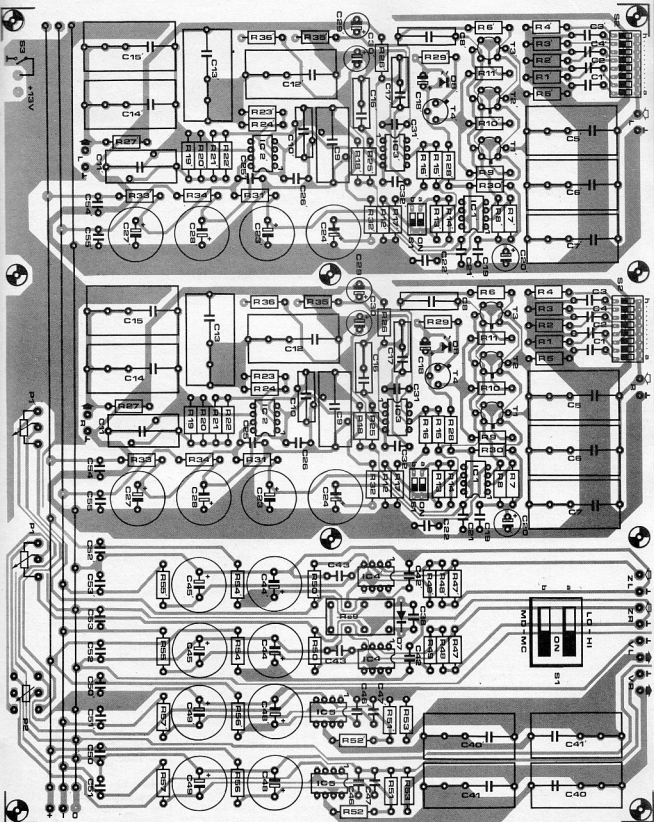

Fig. 15. The mother board.



Fig. 16. The foils for the front and rear panels.

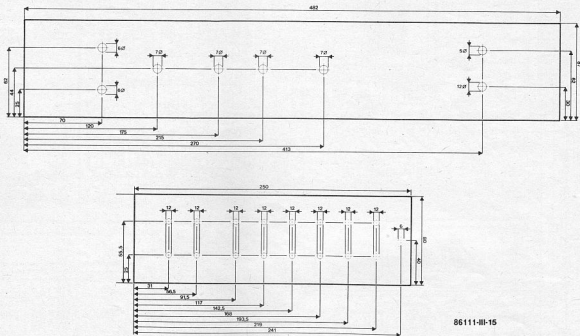

Fig. 17. Template for drilling the front and rear panels.

the pins a few millimetres above the board (see Fig. 14). Next, all connecting points should be fitted with soldering pins. At this stage, only the pin for the earth connection to the supply board should be soldered to the screening layer at the top of the mother board. Finally, the board is cleaned, and its track side insulated with plastic spray, in the same manner as the bus board.

The mother board can then be mounted in the enclosure. All connections to switches and potentiometers can then be made, as can those between the mother and bus boards (at the right of the motherboard at the line section). Screened cable is not necessary for the latter, as these connections are only a few centimetres long.

Next, the connections between the supply and mother boards

are made.

The switching connections to the bus board may be made from flat cable terminated at both ends into a plug to mate with the corresponding sockets on the boards. It should be noted that socket K₁ on the bus board is fitted 180° different from the position shown in Fig. 4 on page 43 in the November issue of *EE*. In reality, pin 1 is located where

pin 10 is shown.

Finally, the connections between the MC-MD sockets and the associated inputs at the mother board, and those between the MC-MD amplifier output on the mother board and the bus board should be made. These should be in good-quality screened audio cable or flexible coaxial cable (TV type). When all connections are made and checked, the mains may be

Table 3

Technical specification

Input sensitivity

Phono: MC (low)	0.1 mV into 47K
MC (high)	0.2 mV into 47K
MD (low)	2 mV into 47K
MD (high)	4 mV into 47K
Tape, tuner, aux	200 mV into 45K
CD	400 mV into 20K

Maximum input voltage at 1 kHz

Input-line out:

Phono: MC (low)	1 mV
MC (high)	2 mV
MD (low)	20 mV
MD (high)	40 mV
Tape, tuner, aux	2 V
CD	4 V

Input-tape out:

Phono: MC (low)	6 mV
MC (high)	12 mV
MD (low)	120 mV
MD (high)	240 mV

IEC (RIAA) correction

± 0.2 dB over the frequency range of 20 Hz to 20 kHz. Standard input impedance: 47K; standard input capacitance: 50 pF. Values can be preset from 10R to 47K and from 50 pF to 500 pF.

Output (line out)

Nominal output voltage	1.2 V
Maximum output voltage	10 V
Output impedance	<100R
Maximum output current	20 mA

Third-harmonic distortion

(at 1 kHz)

output voltage	100 mV	1.2 V	10 V
Phono: MC (low)	<0.1%	<0.01%	<0.02%
MC (high)	<0.05%	<0.01%	<0.02%
MD (low)	<0.01%	<0.005%	<0.02%
MD (high)	<0.01%	<0.005%	<0.02%
Tape, tuner, aux	<0.005%	<0.005%	<0.02%
CD	<0.005%	<0.005%	<0.02%

(over range 20 Hz to 20 kHz and output voltage of 1.2 V)

Phono: MC	<0.02%
MD	<0.01%
Tape, tuner, aux	<0.008%
CD	<0.008%

Intermodulation distortion

(60 Hz: 7 kHz; 4:1; SMPTE)

Tape, tuner, aux, CD	<0.003%
----------------------	---------

Signal-to-noise ratio

(inputs short-circuited; output 1.2 V)

Phono: MC (low)	>70 dB
MC (high)	>76 dB
MD (low)	>86 dB
MD (high)	>92 dB
Tape, tuner, aux	>105 dB
CD	>105 dB

Line amplifier

(terminated into 47K)

Frequency range	10 Hz - 50 kHz (± 0.1 dB)
	1.5 Hz - 500 kHz (-3 dB)
Phase characteristic	$< \pm 0.5^\circ$ (15 Hz - 120 kHz)
Cross-talk (at 10 kHz)	
line inputs (L \leftrightarrow R)	< -70 dB
L/R to other inputs	< -80 dB
Slew rate	> 4 V/ μ s

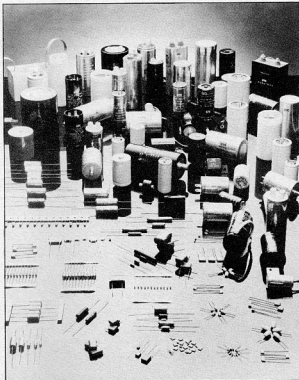

18

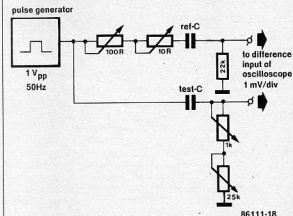

86111-18

Fig. 18. Circuit for making comparative measurements of different types of capacitor.

switched on. Adjust P_1 and P_2 to obtain exactly ± 18.5 V on the supply rails on the mother board.

Next, measure the direct voltage at the output (pin 6) of the LF411 (IC₂); this should not be more negative than -14 V. If it is, lower the value of R_{15} till the reading is -14 V. This voltage depends to a large extent on what make of input transistors is used; normally, R_{15} need not be altered from the

stated value. As a safety check, measure the direct voltage at the output (pin 6) of IC₂; this should be not more than 5 mV, and preferably 0 V.

The preamplifier should amply meet the specifications given earlier, which are minimum values. The prototypes exceeded the figures given in almost all cases: for instance, distortion measurements gave values that were only about half the figures stated.

ELEKTOR INDIA TEST EQUIPMENT

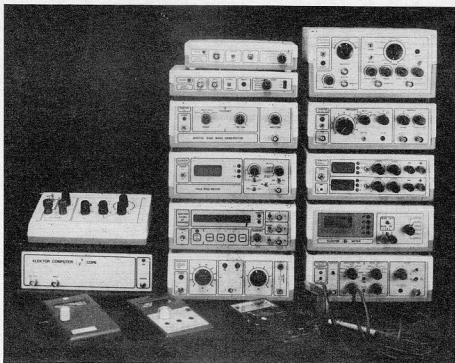

As reported elsewhere in this issue, this month we start a regular series of reviews of a variety of test and measurement equipment. The series starts with a review of a number of dual-trace oscilloscopes, and will continue with storage oscilloscopes, signal generators, power supplies, multimeters, frequency counters, pulse generators, LCR meters, and more. Since it is, however, appreciated that many readers in schools and small workshops, laboratories and electronic design centres remain interested in constructing some test equipment themselves as an attractive alternative to the more costly commercial equipment, we thought it helpful to remind you all of the number of test equipment projects that have been published in *Elektor India* over the past few years. The accompanying photograph shows that the majority of the *Elektor India* instruments are housed in a standard Verobox enclosure, which makes for a neat and uniform appearance.

A comprehensive series

Shown to the left in the photograph is the LCR Meter on top of the Computerscope. Below in the centre stack is the Loudspeaker Impedance Meter. Then come the Microprocessor Controlled Frequency Meter, the True RMS meter, the Digital Sine-wave Generator. The 2-channel and standard, single-channel, version of the VLF Add-on Unit for Oscilloscopes seen on top of the stack are housed in flat Verobox enclosures. The right-hand stack is composed of the Pulse Generator at the bottom, supporting the Digital Capacitance Meter, the Dual Variable Power Supply, the Function Generator, and the Spot Sine Wave Generator. Seen in front are, from the left to the right, the Altimeter/Barometer, the Autoranging Digital Multi-meter, and the Temperature Probe plugged into a DMM. No attempt was made to photograph all published items related to electronic test and measurement—not shown for

instance, are the analogue Capacitance Meter, the Audio Sweep Generator, and a host of smaller projects for testing components, AF, RF and digital circuits.

Overview of publications:

- *Audio Sweep Generator*: December 1985.
- *Autoranging Digital Multi-meter*: July 1987.
- *Capacitance meter* (digital): March 1984.
- *Capacitance meter* (analogue): June 1987.
- *Computerscope*: November 1986 and February 1987.
- *Digital Sine-wave Generator*: March 1987.
- *Function Generator*: January 1985.
- *Loudspeaker Impedance Meter*: October 1986.
- *Microprocessor-controlled Frequency Meter*: February 1985, and March 1985.

- *Pulse Generator*: May 1984.
- *RLC Meter*: March 1985.
- *Spot Sine-Wave Generator*: June 1987 and July 1987.
- *Temperature Probe for DMM*: January 1987.
- *True RMS Meter*: January 1987.
- *Variable Dual Power Supply*: May 1986.
- *VLF Add-on Unit for Oscilloscopes*: March 1987.

what's watt?

The most 'interesting' figures on the specification list of an audio power amplifier are those relating to the rated output power. This article reviews the various kinds of watt that one can meet in a specification. Since the purpose of using the amplifier is to reproduce music at a 'correct' level, it will also be necessary to consider the efficiency of the loudspeakers that are to be driven.

It is rather too easy to manipulate with the 'watts' in the power-amplifier specification to produce an inflated rating. The idea is to sell a relatively low-power job to the unwary — at a high-power price — on the premise that all the fellow wants is a higher watt-rating than the chap next door. This technique has been developed to such a fine art that there are even protests from within the industry — from responsible manufacturers and their associations — hampered, unfortunately, by the fact that it is not immediately obvious just what *is* a realistic watt-rating.

Well, . . . what's watt?

It seems logical to assume that the maximum 'undistorted' sound level a given combination of amplifier and loudspeakers will produce depends on the maximum amount of 'undistorted' drive power available.

The assumption is correct, up to a point — the point at which the loudspeaker becomes the factor limiting a further increase in the 'undistorted' sound pressure.

Whichever factor sets the limit, there comes a setting of the gain control at which the reproduction is no longer 'undistorted'. Some listeners immediately detect this as a 'rough edge' to the loud music passages, others actually like the effect — and happily turn the 'fi' up 'hi'er.

When the system really saturates (so that there is quite unmistakable severe distortion) the usual reaction is to assume that the power amplifier is 'clipping'. That may well be — but it 'ain't necessarily so'. The discovery is invariably made too late, after an investment in new parts or in a new ready-built amplifier of higher rating has failed to noticeably increase the available 'racket'. What *has* happened is that more watts have become available for heating up the speaker's drive-coil (and possibly tearing the cone loose from its moorings). This can easily mean a further considerable investment — and this time without a trade-in!

It is one of the physical facts of life that a high quality loudspeaker of reasonable dimensions inevitably has an efficiency — i.e. the ratio of acoustic watts delivered to electrical watts consumed — in the order of 1 . . . 5%. The balance is simply waste heat!

The distortion in the sound radiation from a loudspeaker, as a function of the applied drive-power, is a difficult thing to measure. One therefore rarely finds figures on this in the manufacturer's published specification. The situation regarding permissible drive power seems to be this: there are two limiting factors to the drive power a given loudspeaker will 'accept'; there is the instantaneous peak power input at which saturation-distortion or even actual mechanical damage will occur, and there is a considerably lower continuous power level (certainly in the case of mid-range and tweeter units) at which the continuous

heat production causes the maximum allowable temperature rise in the 'motor' (i.e. the moving coil). A measurement with a steady sinewave as loudspeaker drive will encounter the latter limit first, so that some kind of 'tone burst' seems to be required. The duty-cycle of this tone burst needed to bring the limits together would have to be determined for each type of loudspeaker tested and quoted in the specifications — assuming that this is meaningful to the customer working out the permissible amplifier rating!

Manufacturers would clearly prefer a standardised procedure that would enable dissimilar units to be compared by prospective users. Presently used test signals are therefore obtained by 'frequency-weighting' a wideband noise signal until its spectral power-density (both 'instantaneous peak' and 'continuous') corresponds to that of 'typical' music (whatever that may be). This solves the maximum-power problem nicely — but not the distortion-measurement one.

If the customer is going to use a power amplifier capable of overheating (or mechanically overdriving) any of the loudspeakers in the system, he will simply have to refrain from doing silly things with the volume and tone controls. Damage rarely occurs before severely-distorted reproduction has given fair warning . . .

Amplifier sinewave rating

The amplifier's 'continuous' or 'sinewave' rating is, to put it crudely, its heating-ability. The rating is obtained by having the amplifier deliver a steady sinewave output of specified frequency, into its rated load resistance — at a level for which a specified small deviation from the input waveform (i.e. a specified amount of distortion) is caused by non-linearities in the output circuit. Manufacturers normally specify a level that the worst product made (due to component tolerances etc.) will reliably meet.

A stereo power amplifier is invariably

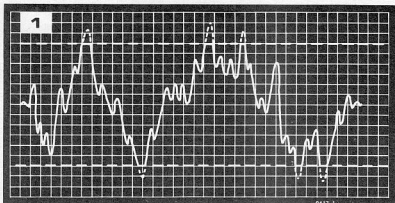

Figure 1. There is a limit to the positive or negative output voltage swing, set by the operating conditions. The dashed curve shows an attempted 'overdrive' waveform, the solid curve shows the 'clipped' output waveform actually obtained.

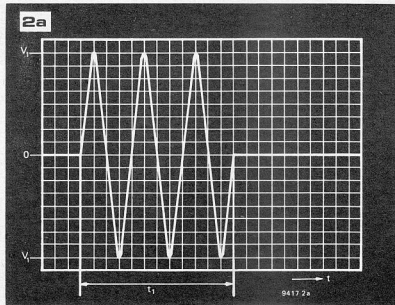
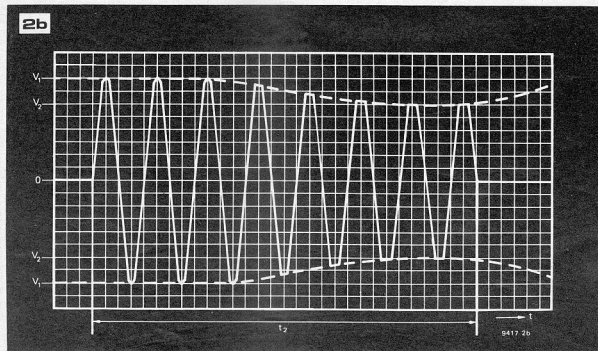

Figure 2. When the duty cycle of the input signal, in this case a tone burst, is sufficiently small, the clipping levels are approximately those due to the quiescent supply voltage V_1 (2a). Interval t_1 is then short in comparison with the supply time constants. The longer interval t_2 (2b) corresponds to a higher average power, causing the supply voltage to fall (ultimately to 'full load' V_2), so that the originally unclipped waveform becomes distorted. V_2 is the level during the troughs in the ripple waveform, not the 'average' value of the DC supply.



rated on the basis of 'both channels driven' simultaneously – the situation that makes the severest demands on the power supply circuits.

What one actually measures in this test is the maximum average power, equal to the product of 'effective' ('RMS') voltage across and 'RMS' current through the load resistor. The Root Mean Square value of a time-varying quantity is its mathematically-derived 'effective value': the value of a steady direct voltage or current of the same heating ability. The intermediate values within a representative time-interval are 'squared', then the squares are 'meant' (averaged) and the 'root' of this average taken as the result ('the root of the mean of the squares'). For a sine wave the RMS value is known to be 'one over root two' (about 0.71) times the peak value.

One occasionally encounters a 'continuous peak' power rating. It is the product of peak voltage and peak current (i.e. 'squarewave power') and is precisely twice the sine wave rating – its only claim to (commercial) merit.

The value of a 'continuous' rating is that it enables one to make objective comparisons between different amplifiers. It also provides a 'reference' output level at which a distortion measurement (necessarily a steady-state operation) can be carried out. Assuming that the system limitation is not in the loudspeakers, since if it were the whole matter would become rather complicated, the question can be raised: to what extent is the sine wave power rating of an amplifier relevant to its ability to deliver an undistorted music signal?

The waveform of a music signal is rarely even remotely similar to a sine wave form. The ratio of peak value to RMS value (the 'crest factor') can exceed 15 dB for much of the programme, depending of course on the kind of music involved and on the extent to which dynamic-range compression has been applied during recording and transmission. When the music signal is driving the amplifier momentarily just to its peak output (i.e. genuinely undistorted full-drive), one may assume that the average power delivered will be well below the amplifier's continuous rating. Let us not complicate matters by trying to account for the effect of current limiters in the output stage. The simple situation is that the amplifier's peak power capability is determined by the momentarily available supply voltage. There will come a point (see figure 1) at which the 'on' transistor 'bangs its head' against the supply rail – the waveform being flattened ('clipped') by the inability to go higher.

Music power rating

The specification sheets of many commercial amplifiers give not only the continuous power rating, but also the 'music power'. This latter figure is then always higher than the continuous figure. The music power rating does not follow any standard measurement

procedure; it is simply an indication by the manufacturer of the output power his amplifier will momentarily deliver (i.e. during instantaneous peaks in the music signal).

One must therefore be careful when comparing amplifiers on the basis of their music power ratings. On the other hand, the rating is quite relevant to the unit's performance in a practical situation and cannot be dismissed as a mere commercial trick.

The essence of the 'music power' concept derives from what (watt) happens when the amplifier's power supply circuit is not voltage-regulated. The situation is that an undriven class B output stage draws only a relatively small standing or 'quiescent' supply current, so that the fairly hefty reservoir capacitor has no difficulty in providing an almost ripple-free feed voltage close to the peak value of the transformer secondary 'open' voltage. When drive is applied there will be a tendency for the feed voltage to drop (and for the ripple to increase) – causing the 'clipping level' of the amplifier to fall. This process takes time however (because of the aforementioned hefty reservoir capacitor) – so that a momentary full power demand will be met at full voltage. Only when the average demand becomes appreciable will the supply voltage reduction noticeably reduce the available output power. Note that the relative power reduction is roughly proportional to the square of the relative voltage reduction, because a reduced voltage swing inevitably means also a reduced current swing – and the product of voltage and current is power. Figure 2 illustrates the on-load behaviour of the simple supply circuit of figure 3. Charge flows out of the reservoir at a rate proportional to the current demanded (charge is measured in ampere-seconds). The charge loss has to be made good by a surge-current, that occurs one hundred times per second,

whenever the instantaneous secondary voltage (minus the drop in the rectifier diodes) exceeds the voltage across the capacitor. The internal resistance of the rectifier circuit (actually the effective 'copper resistance' of the transformer windings) determines the magnitude of these surges – and therefore the drop in supply voltage that must occur with a given combination of capacitor value and load current. V_1 is the no-load (or better 'quiescent load') supply voltage; V_2 is the considerably lower full-load voltage (continuous full drive). The charging process occupies a greater part of the hundredth-of-a-second (mains half-wave) interval – and the voltage drops much faster during the full-load discharge process. It will not be difficult to see why power-electronics have a 'permissible ripple-current' rating in addition to their nominal capacitance! The designer of the power supply has to make a difficult choice here. A very low transformer winding resistance (both primary and secondary) will make for a very 'good' supply. It unfortunately also means a relatively bulky and expensive transformer – and a more violent 'switch-on'.

Note that providing electronic regulation of the power supply circuit will enable the 'continuous power' to be made equal to the 'music power' rating – but at the price of more transformer, more electrolytic and more heat sink! The only advantage of regulation is that the output stage can be continuously operated closer to the transistor voltage maxima, without requiring allowances for mains voltage tolerances. In return for the hardware investment one obtains, in essence, that a power rating slightly higher than even the permissible 'music power' can be guaranteed under all load conditions. This may be justifiable under certain professional circumstances.

After all that ... what's what?

The 'continuous' and the 'music' power ratings of an amplifier give information that is relevant to the unit's ability to deliver an undistorted audio signal.

All other power ratings, such as 'square-wave power', 'peak music power', '±2 dB power' etc., reflect more upon the abilities of the advertisement copywriter.

The amplifier's power rating is by no means the only parameter – or even the most important one – relevant to the enjoyment of undistorted music reproduction.

Figure 3. A typical unregulated power supply circuit, in this case with symmetrical positive and negative output rails. The resistance shown as R is in fact due to the copper-resistance of the transformer windings and the series resistances of the rectifier diodes. At a given load demand, a larger value for the reservoir electrolytics will enable a longer 'burst' to be met at full power – but the recovery time will then also be greater.

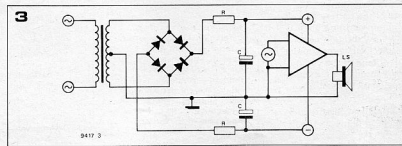

CHARGING/ DISCHARGING CURRENT METER

When the car battery is down without giving any prior intimation, you can always read it on the face of the car owner, trying desperately to start his car in the morning.

Cursing the battery is not going to solve the problem. It would have been a lot easier if there was a way to find out that the battery is getting discharged quickly. The electronics hobbyist can think of a solution for this problem, a simple micro ampere meter and a few components are enough for building the Charging/Discharging Current Meter for your car.

Figure 1 shows the construction and figure 2 shows the circuit of the apparatus. Our measuring circuit is connected in parallel with the earthing cable. A very small percentage of the current flowing between the minus pole of the battery and the common earthing point will now flow through our circuit. Exactly how much percentage of the current flows through the meter is decided by the setting of the potentiometer P1.

The practical construction is shown in figure 1. The

potentiometer should not be left floating in air as shown in the illustration, but it should be fixed on a small bakelite strip. This bakelite strip can be fixed on to the meter itself through its screws.

Make sure that no lights or any apparatus is connected directly to the minus pole of the battery. This must be so, because all the current being supplied by the battery during charging, or being drawn by the battery during charging, must pass through the earthing cable across which we have connected our measuring circuit.

As the meters available are of various different sizes,

Figure 1:
A simple centre zero meter with a potentiometer and a diode is all that is required to build the charging/discharging current meter.

Figure 2:
The circuit diagram of the charging/discharging current meter. The circuit is connected between the minus pole of the battery and the common earthing point on the body of the car. No lights or other apparatus should be connected directly at the minus pole of the battery.

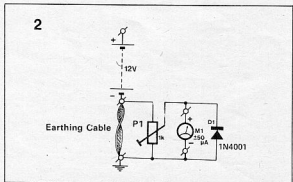
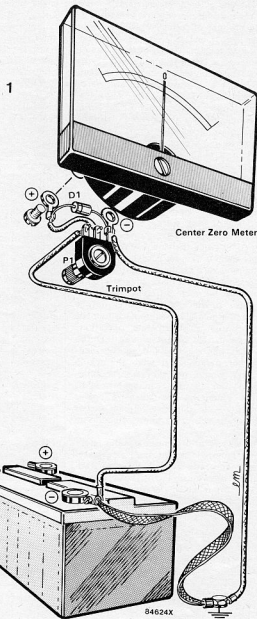

everyone must think of his own procedure for fixing the meter and the circuit.

You can buy any center zero meter with 50-0-50 μ A rating, that is, a meter which has a zero in the centre of the dial, -50 μ A on left side full scale, and +50 μ A on the right side full scale of the dial. As the accuracy required is not very critical you can even use a cheaper centre zero meter used in radios and stereos.

The left and right full scale points of the scale are to be marked with -30A and +30A.

The center zero meter is a must because we want to indicate charging as well as discharging current from the battery. After completing all the connections, the ignition is

switched on. For alignment, we can use the current that is used by the dimmers.

First with all lights switched off, the zero adjustment is used to set the needle of the meter to zero. Then the dimmer is switched on, knowing the power required by the dimmer is necessary to calculate the current drawn. 45/40W systems generally draw about 8.5 A in the dimmer position and 60/55 W systems generally draw about 11 A in dimmer position.

To avoid misinterpretation of the current drawn, it is better to insert a paper between the ignition contacts during calibration of the meter; so that the current drawn is only the current for dimmers. The needle of the meter swings towards left, showing that the battery is supplying current. The potentiometer

is adjusted so that the meter reads the known value in amperes on the dial marked from 0 to -30 on the left side.

Now to see how the charging current is indicated by our meter, first remove the paper that was inserted between the ignition contacts. Start the engine and keep it running. The starting current is quite large but it does not damage the meter as we have connected a diode across the meter in our circuit. The diode is connected with cathode at plus pole and anode at the minus pole of the meter. The charging current can be checked even with a battery charger, with the minus pole of the charger connected to the common earthing point and the plus pole connected to the plus pole of the battery.

Parts list

P1 = 1 K/L trimpot with knob
M1 = 50 μ A Center Zero meter.
D1 = 1N 4001 diode

Figure 3:
Photograph of the charging/discharging current measuring circuit.

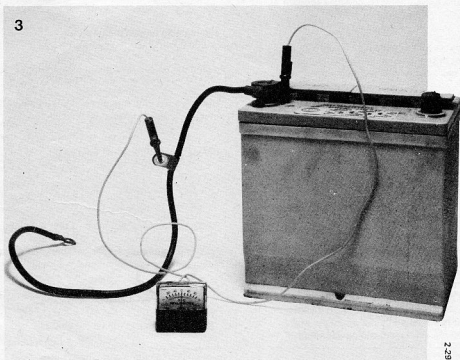

2
5
B

POWER AMPLIFIER

"I want to build a power amplifier for my cycle!"

"A power amplifier?"

"Yes!"

"For the bicycle?"

"Yes, I want more power from the dynamo, so that I can connect more lights to it, or I can get a more powerful headlight."

"Oh, if you think it was so easy, why no one else has thought of it before?"

"I don't understand myself, why no one else thought of it before."

"Because it is not practically possible. You can't amplify the power of the dynamo with an amplifier. You must install one more dynamo if you want more power."

"But, with two dynamos, I have to work harder driving my bicycle."

"That's how it is. You cannot get more power out of anything without putting more power into it. Not even from an amplifier."

"Then why do you call it a POWER AMPLIFIER?"

"An amplifier amplifies power, it does not generate power. It can amplify a weak signal with the help of an additional power supply. The signal from the record player or the cassette player is too weak to drive the loudspeaker, so it is amplified by the amplifier, and it draws the necessary power from the power supply."

"Exactly, something like that I need for my dynamo"

"Then you will also need a power supply for your

Dynamo Amplifier, and you will have to connect it to the mains!"

"Oh, well, but if I could connect the mains supply to my cycle, I wouldn't need the dynamo either. I can connect the headlight directly to the mains"

"You are right, moreover, the output power of an amplifier is much smaller than the input power."

"You mean power is lost in the amplifier?"

"Yes, a 90 + 90 W stereo amplifier takes about 320 W power from the mains and the remaining power is lost as heat."

"Heat is also power?"

"Naturally, power is required for generating heat"

"Now I understand, the power input is equal to the power output and the losses put together"

"Unless the device stores energy."

"Like an accumulator?"

"Yes, you are right, but even in that case, the stored energy is later given out by the accumulator. If you take this power output into consideration, the effective output will always be equal to the input."

"Does your stereo amplifier always consume 320 watts of power? That's a lot of power for an amplifier."

"No, it does not always consume that much power. It is the specified power input when it is actually delivering the specified power input when it is actually delivering 90 + 90 Watts to the speakers. Generally it operates at much lower output power, and the power drawn from mains is also just what is required."

NEW PRODUCTS • NEW PRODUCTS • N

DIGITAL DISPLAY DD-3

"Aqeel Enterprises has introduced Digital Delay DD-3 for Entertainment & Orchestra Programme. This is analog type using BBD delay System. The delay time can be varied from 20 ms to 500 ms as per specific requirement. For musical notes of longer duration long delay will be needed where as notes changing at a faster speed lesser delay time. All this is possible by controlling the 'DELAY' control and 'REPEAT' Control. Microphones inputs have provided for Misc use.

The Digital Delay DD-3 employ the latest and most advanced design and circuitry. Excellent performance and stability under extreme operating conditions and voltage fluctuations is ensured to maintain high quality and satisfaction for the user.

The Mixer can be put to varied uses. A good artist can achieve excellent sound effects by selection of various controls of the mixer.

There are different models to suit different requirements (STEREO & MONO).



For further details please contact:

M/s. AQEEL ENTERPRISES
404, Gali Matia Mahal,
Jama Masjid,
Delhi 110 006.
Phone: 267902

PROXIMITY SWITCHES

Hans Turck GmbH & Co. KG., situated at Mulheim in West Germany manufacture Inductive and Capacitive Proximity Switches.

Proximity Switches with sensing distance upto 60mm. and with other technical parameters are available for use in every application.



For further information please contact:

ARUN ELECTRONICS
PVT. LTD.
2-E Court Chambers
35 New Marine Lines
Bombay 400 020
Phone: 259207/252110
Telex: 11-6136 PREN IN

JOYSTICKS

"Datec Pilot" computer-compatible joysticks are reported to be only indigenously manufactured joysticks for personal computers. The joystick is useful add-on for personal computer users in defining X, Y co-ordinates in CAD/CAM programs, various controls, picture disposition and of course in spare time, for playing games.

At present three types of joysticks are manufactured.
* "Datec Pilot pc" for IBM PC & PC/XT compatible,
* "Datec Pilot bb" for BBC & SCL Unicorn,
* "Datec Pilot ap" for Apple II computers.

The Datec joysticks is indigenous. It does not need any interface and plugs directly to the game I/O port or the Analogin port of the computer. It is housed in a

sturdy cabinet and has sober colours to match computer environments. It has proportional-control and omni-directional capability. It has an auto centering mechanism and is built for easy handling and smooth operation.



For further information please contact:

DATEC PLOT
3/23 Desai Building
83 Mughbat Lane
Bombay 400 004
Phone 342787

LUXMETER

OPTO India has introduced sensitive and Portable. LUXMETER for measurement of light levels. This is suitable for all photometric measurement in science and research as well as quality testing labs.

Its response is claimed to meet with internationally accepted standard CIE observe's curve (equivalent to average-human eye response) with cosine



correction. The range of the instruments are 0-1999, 0-19990, 0-199900.

For further information please contact:

AGARWAL SALES
ENTERPRISE
34, Ganesh Bazar
Jhansi 284 002

PCB TERMINALS

Asia Electric Company have now introduced PCB Terminals which are specially designed for electronic Printed Circuit Boards. Named as Type MUT 2.5, these individuals can be stacked together, for the required number to form a Multiway suitable for international standard module dimensions.

The connection is by soldering pins on the Printed Circuits Board and screw clamping the wire termination. The size of the conductor is upto 2.5 sq. mm and is rated at 500V-15 Amps. The housing is moulded from special grade Industrial Polyimide.



For further information please contact:

ASIA ELECTRIC COMPANY
Katara Mansion, 132A,
Dr. Annie Besant Road, Worli
Naka, Bombay 400 018

NEW PRODUCTS • NEW PRODUCTS • N

MOTOR DRIVER

The L6202/03 is a high efficiency mixed technology motor drive IC (60V, 5A). MULTIPOWER BCD is a new technology which combines bipolar, CMOS and POWER DMOS on the same chip. Both, technology and circuit have been developed by SGS.



For further information please contact:

M/s. SGS
SEMICONDUCTORS (PTE)
LTD.
28 Ang Ko Kio Industrial
Park 2, Singapore 2056

HIGH PRECISION DC SHUNTS

High Precision DC Shunts with accuracy class 0.2 calibrated on Micro-Processor based Test Bench is now available. Temperature stability in the order of 10 PPM ohms. Ratings upto 2000 Amps available, with 75 mV.

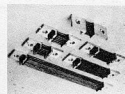

For further details please contact:

AUTOMATIC ELECTRIC LIMITED
Rectifier House, Wadala
P.O. Box No. 7130
Bombay 400 031
Phone 4129330
Telex 11-71544

IONAIRE

"Ionaire is an electronic negative-ionized-oxygen generator manufactured with knowhow from Innovative Systems, USA which creates a fresh, invigorating and clean atmosphere by ionconditioning and cleansing the air of all pollutants and suspended particles. Health-giving ionized oxygen, which is depleted from the air due to various factors like pollution, is replenished by this device. Ionaire finds application in offices, photographic and other laboratories, computer rooms, homes, restaurants, hospitals, clinics etc."

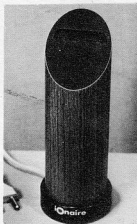

For further information please contact:

M/s. ZEEBETRONICS
16, Commissariat Road
Bangalore-560 025
Phone: 572365

MARKEM PRINTER

The 527 system is designed for small production runs as well as special or pilot lot applications. Capable of printing up to a 1" x 2" (25.4mm x 50.8mm) area, the 527 will mark your DIP's, card edge connectors and other large components having at least one flat surface. Print quality and registration are maintained

by means of easy adjustments and a precision worktable assembly.

Motor driven and actuated by a foot switch, the model 527 will cycle at rates of upto 3000 per hour. The ink plate system is compatible with the entire range of MARKEM inks and is extremely easy to clean.

Specifications: Imprint area 1" x 2" (25.4mm x 50.8mm), Max. part thickness 1-3/8" (34.92mm), Cycle rate Upto 3000 cycles/hour, Mount Bench, Weight (approx.) 35 lb (15.9 Kg.).

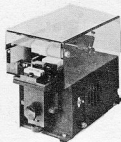

For further information please contact:

KELLY CORPORATION
1413, Dalamal Tower
Nariman Point
Bombay 400 021
Phone: 244286
Telex: 11-5858 KELY IN

ELECTRONIC SOFTSTARTERS

Jeltron series LC1 manufactured in technical collaboration with M/S. Motortronics, Inc. of U.S.A. are Low Cost High Performance Electronic Softstarters for three phase induction motors. The LC1 applies a gradually increasing voltage which in turn provides a smooth, stepless, adjustable acceleration at the time of starting the motor. A second starting ramp is available as an option for the applications where the motor has to start with different loads at different times. Also, for the

friction loads which stop too abruptly with a jerk, an adjustable smooth stop option is available which ramps down the applied voltage linearly in a predetermined time. The starting torques and start times for both the start ramps as well as the stop time are field settable. These starters are available for motors ranging from 2-700 HP.

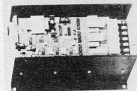

For further information please contact:

M/s. JELTRON
INSTRUMENTS INDIA
PVT. LTD.
6-3-190/2, Road No. 1
Banjara Hills
Hyderabad-500 034

AUTO RANGE PANEL METER

PRESTIGE ELECTRONICS introduce their Autoranging digital Panel Meter Display is 3 1/2 Digit 12.5mm Red, Green or Yellow. Range selection is automatic depending on input voltage. Ranges are 1.999V, 19.99V, 199.9V & 750V DC overall accuracy is 0.25% ± 1 Digit for DC & 0.7% ± 1 Digit for AC models. Dimensions are 48 x 96 x 90mm (1/2 Din size) Cutout 45 x 96mm. Input supply is 230V ± 10%.



For further details contact:

PRESTIGE ELECTRONICS
62/A, Pushpa Park, Malad (E)
Bombay 400 097
Tel: 693805

TAMAYA DIGITIZING AREA LINE METER

Planix 5000 Area Line Meter
Works on a totally new concept developed through unconventional approach leading to unsurpassed performance standards.

The rotary encoder and the state-of-art electronics makes Planix 5000, easiest, fastest area Line Meter. This Meter allows you to measure area and the length of the line. The standard lines are easily measured by simply setting the trace point at each intersection of the figure and the rest is done by the built-in computer with a resolution of 0.05 mm; length of curve line needs to be traced, for measuring.

Planix 5000 is a TOTAL STATION for the draftsman. In addition to its own microprocessor, PLANIX 5000 will interface with the large computer or other RS-232C compatible units. PLANIX 5000 is a compact cordless instrument operating on NiCd Batteries and comes in a carrying case.



For Further details please contact:

TOSHNI-TEK INTERNATIONAL
267 Kilpaik Garden Road
Madras 600 010

SPIKEBUSTER

MAGNUM ELECTRIC COMPANY PVT. LTD. has introduced a voltage spike and noise suppression outlet strip called SPIKEBUSTER. It consists of an EMI/RFI filter and a voltage spike protection circuit built into

a power strip with three 5 Amp sockets and a control switch. By plugging SPIKEBUSTER into the electricity mains and your sensitive electronic equipment into SPIKEBUSTER, electrical noise and voltage spikes are totally prevented from reaching the equipment and damaging it or causing it to malfunction. Uses are for colour TV sets, VCRs, computers, computer peripherals, medical equipment, electronic instruments, communication systems and other device containing sensitive integrated circuits. The company specialises in power protection equipment and will soon be coming out with a lowpriced standby battery back-up system aimed at the desktop computer market.



For further information write to:

MAGNUM ELECTRIC COMPANY PVT. LTD.
2 Ramavaram Road
Manapakkam
Madras 600 089

THICKNESS GAUGE

General Tools offer a coating Thickness Gauge. For measurement of a non-magnetic coating on a Magnetic metal.

Application :- Measurement of following nonmagnetic coatings on magnetic metals.

- 1) Plating—Gold, Copper, Zinc Tin Chromium, Lead etc.
- 2) Coating—Paint, Resinous coating, Metallic Coating.
- 3) Lining—Resin, Rubber, Paper or any other films of non-magnetic material can

be measured when placed on steel base metal.



For further details contact:

THE GENERAL TOOLS CO.
7, Daulat Mansion
Barrack Road, Behind Metro
Cinema, Bombay 400 020

BARREL PUMP (HAND OPERATED) FOR CHEMICALS & OILS

A hand pump, in all plastic construction, namely Polypropylene (PP) and Thermoplastic Polyester (PBT), is introduced for the first time in India. It is ideally suitable for transfer of chemicals and oils from barrels, carboys, jerry cans, jars etc.

The pump in PP is used for transfer of Acids like Hydrochloric, Sulphuric (Upto 80%) Nitric (Upto 70%), Phosphoric, Acetic, Chromic, Spent Acids etc. It is also used for Inorganic Salt Solutions, Hypochlorite and for Vegetable and Mineral Oils and certain Organic Amines.

The pump in PBT is used for all types of Aldehydes, Ketones, Glycols, Alcohols, Petroleum products and Oils, Acetone and Aniline and their derivatives, Benzene, Toluene, Xylene and their compounds, liquid perfumery products and pesticides, DDB, LAB,

Hexane, Liquid Paraffin and other Acetates, Plastcisers, Chlorinated Solvents, Polyols, Isocyanates etc.

In general these pumps are ideally suitable for transfer of liquid chemicals and oils from barrels and carboys. They offer suction lift of 3 mts, discharge heads of 15mmts and capacity of 30 lpm.

They are extensively used at industries like chemicals, textile processing, pharmaceuticals, pesticides formulation, electronics, PCB Mnfg., sugar mills, dye stuff mnfg., etching plants, degreasing plants, research labs., offset presses, installation where oils, kerosene, diesel are used, and all other places where chemicals and oils are handled.

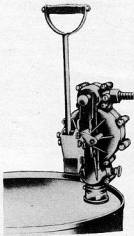

For further information please contact:

CHEMINEERS
6 Jagnath Plot
Rajkot 360 001
Gujarat State, India.

NEW PRODUCTS • NEW PRODUCTS • NEW

DATA SCANNER

Advani-Oerlikon have developed a mini microprocess-based data scanner called UDS-30. This 30-point scanner is designed for scanning of temperature, voltage or any other parameters of water and steam boilers, windings of HP motors and high voltage transformers, distribution points in silos containing foodgrains, engine test and reaction vessels in chemicals and process industries.

The system is field proven, versatile and compact. It is mounted in a standard RA 19 rack. It can accept multi-variable inputs such as Thermocouples, RTDs and Analogues. The system has built-in 24 columns, an alphanumeric 2 colour printer with re-rolling facility which gives out print out of scanned data and programmed parameters. The keyboard functions such as low level set point, control level set points, dwell time, high level set point, channel number, hysteresis, etc. are programmable individually for each channel. Display announcement is provided for each channel. There are totally 90 LEDs. Each channel has a separate indication for alarm, sensor break and control status. The system also has the facility to scan alarm conditions on a priority basis. Output relay contacts are provided for each channel. One relay is provided for common alarm and one for sensor break indication. EEPROM memory is used and hence no battery back up is required for the programme. A real time calendar is also provided which gives date, month, year, day of the week and time. Nickel cadmium battery is provided for the back-up of the calendar. The system uses a floating point arithmetics for linearisation

and other mechanical calculations.

Solid-state semiconductor switches are used for multiplexing, thus contributing to reliability and compactness. STD cards are used for flexibility of operation and ease of maintenance, thus ensuring minimal downtime. The plug-in PCB and the STD mother board have minimised wiring in the instrument. The unit has a hinged transparent unbreakable cover on the front space to avoid any accidental changes in the keyboard function.



For further information, quote ref: PUB/2, contact: ADVANI-OERLIKON LIMITED Post Box No. 1546 Bombay 400 001

SPECTRUM ANALYSER

ROFIN-SINAR LASER UK LTD, announce the introduction of the high speed RSO 6240 Spectral Processor to operate with the current line of Optical Spectrum Analyser equipment. The new instrument includes a more powerful processor, together with many system improvements such as dual double-density double-sided 3 1/2" disc drives, an improved monitor, and digitising electronics.

The entire system has been repackaged with an integral keyboard instead of the earlier separate keyboard. In addition various accessories and software packages have been added to provide a very

powerful package to measure transmission, absorption, reflection and colour, in addition spectroradiometric and software package. The system captures a complete spectrum in 5 msec and stores it in 80 msec in the processor. The wavelength range is 200-5000 nm which can be covered at one time using the "merge" software facility.



For further information, contact: TOSHNI-TEK INTERNATIONAL 267 Kilpauck Garden Road Madras 600 010.

THERMOCOUPLE VACUUM METER

The IBP Thermocouple Vacuum Meter is a simple, single head measuring device.

SPECIFICATIONS

Gauge Head: Chromium plated brass with octal socket. Vacuum Connections: Through standard 6 mm screwed union.

Measuring Range: 1-1000 Microns.

Calibration: Calibrated for dry air using a McLeod gauge. Power Supply: 230 Volts, 50 Hertz, $\pm 10\%$.

Dimensions: Small, compact construction with simple panel installation in Standard half module (H 135 mm x W 210 mm x D 145mm) Standard accessories supplied: Gauge head with cable of length 3 Metres.

Applications: Used in Industrial Systems, Refrigeration Industry, Flask, Lamps, Capacitors and Condenser Industries etc.



For further information please contact:

IBP CO. LIMITED
A Govt. of India Enterprise
Engineering Division
Sewri (East)
Bombay 400 015.

"ROCKER TOGGLE" SWITCH

IEC has just introduced a range of "Rocker Toggle" switches with Black, Red, Blue, White, Yellow or Green colour knobs.

These Rocker Toggle switches are available in 6A, 10A, 15A, 250V AC or 28V DC in single and double pole with on-off, changeover with or without centre off and momentary contact, to serve as Push Button. Special circuits are possible e.g. 1,2,3 or 1, 1+2, 2+3, etc., avoiding the need of 2 or 3 switches.

Switches are supplied with screw terminals or push-in terminals (6.3mm).



For further information please contact:

INDIAN ENGINEERING COMPANY
Post Box 16551, Worli Naka
Bombay 400 018.

classified ads

Instruments Transformers as per specifications. We can also design a single piece for you. Contact: BEA Electronics, 57, Kanti Nagar Gwalior - 474 002, Ph. 24806

AC/DC Solenoid magnets & Electromagnetic Clutches. Contact: BEA Electronics, (Mechanical Division) 57, Kanti Nagar, Gwalior - 474 002, Ph. 24806

Avoid Delay - Get your Printed Circuit Boards designed and made from SHIV ENTERPRISES, P. Bhagat Marg, Tukaram Nagar, Dombivli (E) - 421 201

advertisers' index

ABC ELECTRONICS	1-11
ABR ELECTRONICS	1-14
ACE COMPONENTS	1-73
ADVANCE VIDEO LAB	1-06
BALA JI ENGINEERING	1-08
BMP MARKETING	1-12
CHAMPION ELECTRONICS	1-76
CTR	1-15
CYCLO COMPUTERS	1-04
DESAI ELECTRONICS	1-74
DI ELECTRIC	1-73
DYNATRON	
ELECTRONICS	1-10 1-14
ECONOMY ELECTRONICS	1-10
EFFICIENT ELECTRONICS	1-10
GRAFICA	1-06
G.S. ELECTRONICS	1-14
IEAP	1-14
INSTRUMENT CONTROL	1-08
JM ENTERPRISES	1-09
JR COMPUTER KIT	1-71
JR COMPUTER BOOK	1-71
KIRLOSKAR	1-63
LEADER	1-04
LOGIC PROBE	1-16
MOTWANE	1-07
PACIFIC PRECISION	1-06
PIONEER ELECTRONICS	1-65
PLASTART	1-16
PRECIOUS KITS	1-61
PRECIOUS BOOKS	1-67
PRECISION INSTRUMENT	1-08
PROMOTION	1-04
SIFA ELECTRONIC	1-73
SWASTIK	1-13
TANTIA ELECTRONICS	1-12
TESTICA	1-12
TOPAZ	1-73
VASAVI ELECTRONICS	1-16
VISHA ELECTRONICS	1-75



DEC
Metallised
Polyester Capacitor
Box Type

Now in
5 mm pitch

Range - - 0.01 μ f to 0.47 μ f
Voltage - - 63 VDC
Tan delta at - 1 KHz - less than 0.008
10 KHz - less than 0.015
100 KHz - less than 0.03

Manufactured By

DESAI ELECTRONICS PVT. LTD.

"JAY CHAMBERS" 501, Shivaji Road, Swargate, Pune 411 042.
Ph : (0212) 449148 Grams : DECTRONICS Telex : 145-333 MCCI

BAJGURU

Your Right Connection... Champion

The Champion Connectors!

- o Dual In-line IC Sockets.
- o Single In-line IC Sockets.
- o Pin Grid Array Sockets.
- o Socket Adaptors.
- o Cage Jacks.

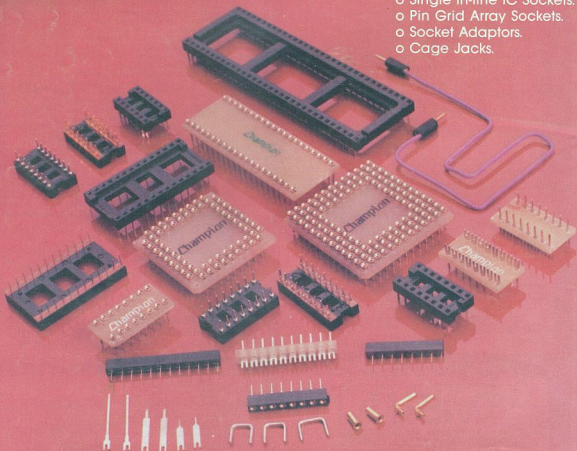

Champion Electronics Pvt. Ltd.

S-17, M.I.D.C. Bhosari, Pune 411 026, India. (0212) 82682, 83791 Cable : CHAMPION
Telex: 0146-343 CHMP IN. 0145-333 MCCI IN. 0145-505 MCCI IN.